



# UNT College of **ENGINEERING**

Senior Design Day 2019



Department of  
**BIOMEDICAL  
ENGINEERING**



# Polar Solace- Back to Action Therapy Solutions

## Team Members:

- Gabriella Bridges
- Daniel Ricano
- Caitlyn Conley
- Taylor Jones

## External Sponsors/Mentors:

## Internal Sponsors/Mentors:

- University of North Texas Biomedical Engineering Department
- Dr. Logan Porter
- Dr. Stephen Black

## Abstract:

Many athletes suffer from sports related injuries, such as muscle sprains and inflammation. There are heating and cooling therapy units on the market. However, these devices can be bulky, expensive, may not provide both heating/cooling, and may require external ice or water. This can limit their usage in terms of cost and location. The Polar Solace is an active heating and cooling therapy unit. This innovative device is affordable, contains a more compact design, and offers both heating and cooling mechanisms without the user having to provide external ice or water. The target market consists of athletes who are in need of immediate pain relief. The Polar Solace is also non-stationary and great for athletes to take on and off the field.

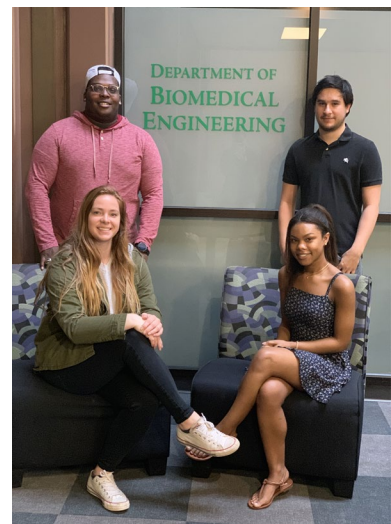

B.A.T.S. would like to say thank you to Jeff Smith and the UNT Athletic Department for testing coordination and Ariandokht Vakili for material purchase and procurement assistance.

# C-Again Glasses: Team BioThinX

## Team Members:

- Mehdi Bennis
- Irving Chapa
- Cera Galecki
- Trey Grantham
- Blake Woodson

## External Sponsors/Mentors:

- Cedric Atkins

## Internal Sponsors/Mentors:

- Dr. Stephen Black
- Dr. Logan Porter

## Abstract:

C-Again optical technology will restore a full visual field to people with blindness in one eye using a specially engineered lens to view a wide-angle live feed. Contained in 3D-printed frames, the device will allow users to capture snapshots and record video of their surroundings. The display of the device also adjusts to best accommodate each user. Although virtual reality has become widely available for entertainment purposes, this device demonstrates a digital environment as an assistive device with high-aesthetic design and low-cost materials.



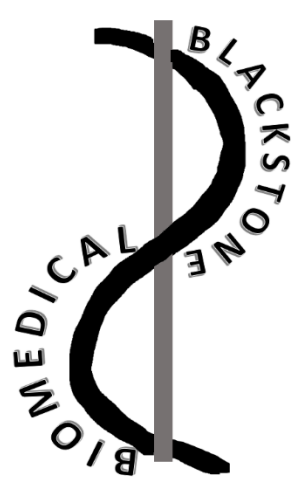

# Casket Digital Footsteps – Blackstone Biomedical

## Team Members:

- Leighton Doolittle
- Michael Joiner
- Chris Lang
- Brittany Schnell

## External Sponsors/Mentors:

- Dr. Tom Black
- Dr. Jared Black

## Internal Sponsors/Mentors:

- Dr. Stephen Black
- Dr. Logan Porter

## Abstract:

Surgical tools caskets currently are manually and physically tagged, resulting in the problems of delayed use and validation of needed tools for surgeries. The Casket Digital Footsteps project primarily creates a method to track caskets in real time, gather locational information, store the information, and search the location of specific tools. This creates a faster and more efficient method for locating surgical tools needed for immediate use.



A special thanks to BlackTechIP, LLC for the opportunity to develop this project and University of North Texas, namely Dr. Vijay Vaidyanathan for the support and guidance through the years.

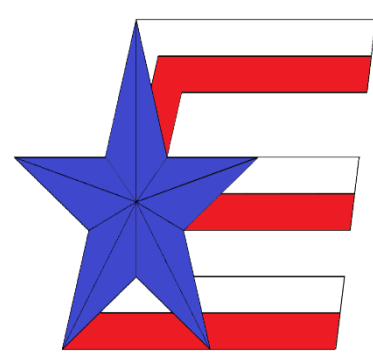

# Etch Cart - Etchronics

## Team Members:

- Sara Hoffman
- Sloan Uys
- Taylor Roof
- Bria Winn

## External Sponsors/Mentors:

- Elvin Cherukunnathu, Parker Hannifin

## Internal Sponsors/Mentors:

## Abstract:

The main goal of the project is to build a working, functional cart that will be portable, easy to operate, and will produce minimal waste. The cart will need to be transported to three different areas on the production floor, depending on the size of the tubing. In one swift motion, once the tubing is extruded from the previous machine, the cart will directly accept the tubing and continue passing it through. All waste will be contained on the cart, with the water and alcohol solutions being filtered and recycled. This eliminates downtime on the production floor and the need to use different operators, therefore, increasing productivity.

# Sleep Steer - iCardioTech



## Team Members:

- Leonie Quaye
- Juanette Boateng
- Aishat Muibi

## External Sponsors/Mentors:

## Internal Sponsors/Mentors:

- University of North Texas
- Dr. Logan Porter

## Abstract:

The SleepSteer is a driver drowsiness alert system that is connected to a steering wheel of a vehicle. The SleepSteer alerts the driver's finger when they begin to experience fatigue. The goal of the SleepSteer is to lessen the rate of car accidents caused by drowsiness on the road. The main objective of the SleepSteer is to incorporate a distributed sensor network into the steering wheel, the sensor network is to be synced with a night vision camera, this combination allows for the calibration and determination of the driver's fatigue levels.



# Paw Scheme



## Team Members:

- Bunyong Dejanipont
- Fernando Chavira Moreno
- Harold Santiago Ramos
- Dan Do

## External Sponsors/Mentors:

- April Becker, Ph.D, Department of Behavioral Analysis, UNT

## Internal Sponsors/Mentors:

- Logan Porter, Ph.D, Department of Biomedical Engineering, UNT

## Abstract:

The cylinder test is the most common analytical assisting tool used to help diagnose the condition of the rat's central nervous system. However, there are drawbacks to this method. This method currently requires researchers to rewatch pre-recordings of these rats, which takes away precious time that can be utilized elsewhere. To address this problem, our team "Paw Scheme" has created a test called "Paw Asymmetry Test" (PAT) to automate the task of the cylinder test. Through the use of Processing 3, an open graphical library, a color code was created that senses the rat's touches with the use of Raspberry Pi touchscreens. This process is then recorded and sent to Google Cloud's object detection services to translate, label, and detect the objects from the recording. Google Cloud's object classifier will detect objects, defined by pre-chosen colors of the touchscreens, that are being triggered by the rat's touch. Lastly, our Raspberry Pi counter script would then maintain a counter to quantify the number of contact points made while indicating which paw(s) made contact. PAT will be the new innovative test that replaces the cylinder test, consisting of Google Cloud's machine vision for training and evaluating customized models.



UNT TRiO student support services, UNT Department of Behavior Analysis, and the Texas state-wide program JAMP (Joint Admission Medical Program)





# PolyRegenEX – Hydrogel Drying Chamber

## Team Members:

- Lauren Vandebroke
- Kris Bickham
- Victoria Glasco

## External Sponsors/Mentors:

- Smith & Nephew

## Internal Sponsors/Mentors:

- Biomedical Engineering

## Abstract:

Smith & Nephew researchers have developed a liquid hydrogel compound that can be dried into a film and applied to the epidermis to clean and prevent infection in chronic wounds typically associated with diabetic patients, geriatric patients, and burn victims. Drying the liquid hydrogel in an open-air drying environment is a time-consuming and inefficient process which can take up to 72 hours. The hydrogel drying chamber (HDC) greatly decreases the amount of time it takes to dry the hydrogel. The HDC processes data from sensors within the chamber to determine the dryness of the film.



# Pectus Excavatum surgical innovation – Xiphos

## Team Members:

- Meshach Jassal
- Andrew Bowley
- Austin Ridwayay
- Ray Habib

## External Sponsors/Mentors:

- Dr. Tom Black

## Internal Sponsors/Mentors:

- Dr. Stephen Black
- Dr. Logan Porter
- Dr. Vijay Vaidyanathan

## Abstract:

Pectus excavatum is a birth defect affecting thousands of children across America. The most prevalent surgical technique requires long hospital stays post operation. Xiphos is designing a new technique that will move away from large, instantaneous force and towards a move a over time correction.



We would like to thank BlackTechIP, LLC for the opportunity to work closely with them and develop their ideas. We would also like to thank The University of North Texas Biomedical Engineering department, namely Dr. Vijay Vaidyanathan, Dr. Logan Porter, and Stephen Black for the support through the years.



Department of  
**COMPUTER SCIENCE  
AND ENGINEERING**



# COMPUTER ENGINEERING

# Securing IoT Team HED

## Team Members:

- Chima Akano
- Justin K. Paul
- Jorge Moreno
- Hector Tamez

## External Sponsors/Mentors:

- N/A

## Internal Sponsors/Mentors:

- Dr. Pradhumna Shrestha
- Dr. Robin Pottathuparambil
- Thomas Kanaby

## Abstract:

IoT devices are growing and have become an important part of embedded systems to handle data for interconnected communication networks. This brings up the importance of securing our IoT devices and maintaining the integrity of the data these devices manage.

The purpose of this project is to identify malicious attacks on a WSN (wireless sensor network) that will consist of four nodes (four raspberry pi's) and a central node (HUB) to gather sensor data. We will then observe how the malicious attacks have infiltrated weak areas of our IoT network and apply countermeasures to resolve the attacks thus keeping our nodes and their data safe. Our proposed solution is to research solutions to secure our IoT network from attacks, and to produce countermeasures to future attacks.



# Team Impulse

## Team Members:

- Gabriel Costa
- Michael Kahn
- Rebecca Molnar
- Alejandro Siller

## External Sponsors/Mentors:

- Dave Perkowski & Cristian Almendariz - All Axis Machining

## Internal Sponsors/Mentors:

- Dr. Pradhumna Shrestha

## Abstract:

All Axis Machining uses a handful of CNC machines for the production and testing of all of the parts their clients order. While this layout allows for the machining of uniform parts with a high accuracy, each of the machines needs to be monitored constantly by on site personnel.

Team Impulse will be working in conjunction with All Axis Machining to implement a central unit that will receive machine status and job progress reports from each of the CNC machines in All Axis Machining's shop. The central unit will then display this information in a custom designed GUI in All Axis Machining's central office. All Axis Machining's employees can then remotely command the CNC machines through the same central unit.

While this information will be accessible at all times from a pre installed TV in All Axis Machining's central office, management will be able to view this information from their personal mobile devices or computers by accessing All Axis Machining's wireless network. The project will facilitate monitoring and managing the machine shop.



# Smart Door

## M.T.E.K

### Team Members:

- Michael Thomas
- Eric Nwokocho
- Kennard Boykin
- Trevor Hendricks

### External Sponsors/Mentors:

- Our project was 100% sponsored internally

### Internal Sponsors/Mentors:

- UNT Computer Science and Engineering Department
- Dr. Pradhuma Shrestha
- Thomas Kanabay

### Abstract:

Our project is a facial recognition device that allows a homeowner or known member of the household to unlock the front door without using a physical key. The device is attached to the front door of a home and works by a user going up to the device, looking into the camera, and then being allowed or denied access to the house.

Implementing this device automates and increases the level of security of the house and ease access as well. The facial recognition is implemented using a Convolutional Neural Network, where a sample value (in this case, a picture received from the camera on the device), is compared to a dataset of correct images for accuracy. This dataset of images for any one person (any one member of the house) is pre-trained for accuracy against a wider array of different faces, so that a specific face is distinguishable from others.

The device will also allow the predetermined head-of-household to allow non-home-members inside the house remotely, through means of a manual override via text message.



# Smart Home for Assisted Living

## Team Lannister

### Team Members:

- Mitchell Clarke
- Anmol Singh
- Prajwal Waiva
- Girard Roston

### External Sponsors/Mentors:

### Internal Sponsors/Mentors:

- Dr. Pradhumna Shrestha
- Thomas Kanabay

### Abstract:

Smart home technology is still fairly new, but it is becoming much more common in modern homes. Families are integrating this technology into their homes to provide better security and an improved quality of life. This technology has not yet branched out past common households yet, but it's the next step for this growing technological innovation.

Team Lannister's smart home for assisted living centers takes smart home and IoT technology and integrates it into assisted living centers to improve the quality of life of each patient and simplify the jobs of every employee.

This system will include a temperature sensor, door sensors for the main doors and medicine cabinet, and a motion sensor inside each room. A smart watch with a fall detection system will also be worn by the resident, along with a Polar T34 heart rate monitor to monitor irregular resident movement and their heart rate.

Data will be sent to and stored in an online database that nurses can access for each patient, and SMS alerts will be sent out if any irregular readings occur.

- Adafruit.com for supplying all of the sensors and microcontrollers used in this project
- Dr. Pradhumna Shrestha for mentoring us and giving us guidance throughout the semester
- Thomas Kanabay for working with us during the parts ordering and design processes





# MetroBand

## Team EyeD

### Team Members:

- David Adeyemi
- Gersom Adu
- William Lewis
- Luke Parks

### External Sponsors/Mentors:

### Internal Sponsors/Mentors:

- Dr. Pradhumna Shrestha

### Abstract:

MetroBand is a smart watch poised to revolutionize the music performance, performing arts, and synchronized sports industries.

The main components of the MetroBand watch are:

- Metronome
- Instrument Tuner
- Metronome wireless synchronization across multiple watches (SmartConnect)
- Normal smart watch functionality (date and time, alarms and timers)

The SmartConnect metronome network will enable effortless collaboration and will synchronize multiple performers who are wearing the MetroBand smart watch.





# Project Status Report 3 Team: 1A4

## Team Members:

- Rad Wadud
- Adesunkanmi Afolabi
- Nasser Alquaihi
- Spencer Igwe
- Laura Kent

## External Sponsors/Mentors:

- N/A

## Internal Sponsors/Mentors:

- University of North Texas
- Dr. Pradhumna Shrestha

## Abstract:

Our project serves to act as a presence detector within a car. The driver is notified when a living being is left behind in the vehicle.

This is feasible through multiple connected sensors which send information to a microcontroller board in the event the received information has met certain conditions that suggest a presence. The board communicates to the app over a wireless internet connection to notify the user via cell phone app.

The app continues notifying the user over a certain period until the user selects to acknowledge the notification.

This can be “Accept” or “Reject” decision. On the chance that the event is a false- alarm, the user is able to select a Reject response to confirm that there is actually no presence. If a being is left alone in the car, the driver choose “Accept” and pick the baby.

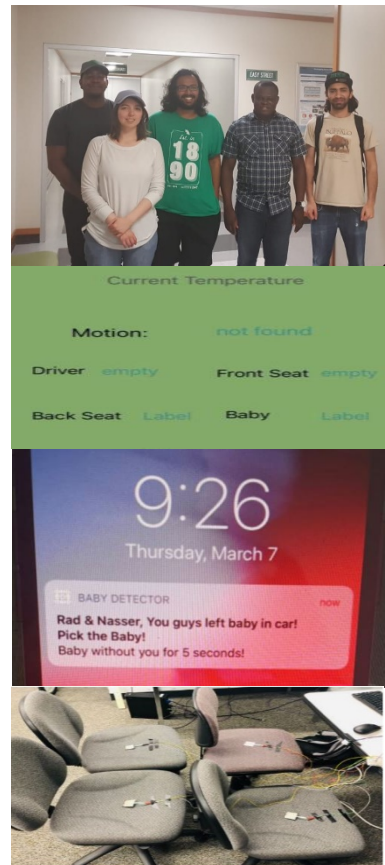

We thank the Project Manager, our professor, Dr. Pradhumna Shrestha who conceptualized the project and piloted us through from beginning to the end.

And Thomas Kanabay who supported us for needed parts on short notices.

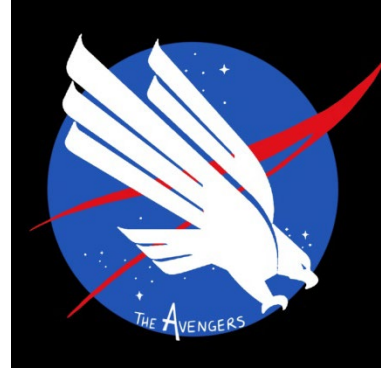

# Spacecraft Lighting Network System Team Avengers

## Team Members:

- Jose Guzman
- Gordon Fields
- James Gonzalez
- Samantha Akos

## External Sponsors/Mentors:

- George Salazar- Nasa Mentor

## Internal Sponsors/Mentors:

- Dr. Robin Pottathuparambil – Faculty Advisor

## Abstract:

The innovative use of network lighting systems has created a solution that prevents radiation from damaging current lighting systems in spacecrafts. In space, Crew members have been using switches and knobs to control the power and light intensities onboard the spacecraft. These components are comprised of parts that are susceptible to radiation and can lead to damage of the lighting system. This proposal is concerned with the design of a Spacecraft Lighting Network System that will use a touchscreen to control lighting intensities and will provide feedback on the lighting system as a whole. Along with an updated approach, fault tolerant features will be in place in case of failure within certain subsystems. These subsystems include the router and switch, the individual slave Pi's, the sensors, and the GUI of the system. The system will also provide a health status of the lights and its life expectancy. With these innovations, our design aims to improve the current lighting systems by removing the conventional use of switches and knobs.



We extend our gratitude to last year's team, 2B! | 2B. We have built on their efforts and contribution to create our own vision on how to accomplish our project's goals. We would also like to thank Dr. Robin Pottathuparambil for his guidance and helpful suggestions when we hit a roadblock. Furthermore, we would like to thank Thomas Kanabay for providing us with parts and equipment he had on hand.



# Sleep Apnea Monitoring System

## Team CMBZ

### Team Members:

- Chris Covey
- Neil Mistry
- Kahale Barnes
- Damian Zubia

### External Sponsors/Mentors:

- Dr. Edwin Simon

### Internal Sponsors/Mentors:

- Dr. Robin Pottathuparambil
- Thomas Kanabay

### Abstract:

Approximately 25 million adults in the United States of America alone suffer from obstructive sleep apnea, according to the National Healthy Sleep Awareness Project. Obstructive sleep apnea is a disorder that causes the patient to repeatedly stop and start breathing during sleep. Current diagnosis standards involve an in-lab sleep study that monitors multiple variables such as respiratory movement, airflow, body movement, heartrate, oxygen saturation, and snoring sound. The diagnosis standard is incredibly time consuming and labor intensive. It also puts the patient in an unfamiliar environment, which can have an effect on the patient's ability to sleep for proper diagnosis. Our goal is to find a way to create a moderately low-cost portable solution so that a patient can administer a sleep study in the comfort of their own home. Our project is to create a patch with unified sensors that collects these pieces of data: Respiratory movement, airflow, body movement, heartrate, oxygen saturation, and snoring sound. Once the data is collected, it will be wirelessly pushed to a network that will then pass it to the cloud for post processing. This data will be collected, stored, and encrypted and will meet the current HIPPA guidelines for patient privacy. On completion, the system will have the ability to be used as the gold standard for the diagnosis of OSA and meet the standards for FDA approval.



Client & Subject Matter Expert: Dr. Edwin Simon

Faculty Advisors: Dr. Robin Pottathuparambil and Thomas Kanabay

Previous team members from Team Snooze



# Vehicle Interchangeable Electronic Controller Networks System (VIEC)

## Team ERAM

### Team Members:

- Edward Escamilla
- Ryan Moye
- Maria Pavloschi
- Alexander Villalobos Quintanilla

### External Sponsors/Mentors:

- George Salazar
- TSGC Design Challenge

### Internal Sponsors/Mentors:

- Dr. Robin Pottathuparambil
- Thomas Kannabay
- Office of the Dean

### Abstract:

As humans push the limits of exploration and the time duration spent in deep space, providing spare spacecraft components becomes more and more critical. While it is too expensive to ship unique spare components to space, nor is it feasible to send the spare components in the initial launch, there are other options.

Therefore, our goal is to create a system that permits interchangeability of vehicle controllers based on where the controller interfaces with the vehicle.

Our method of developing the system of interchangeable controllers is to configure the controllers via interaction with a network server providing information for each controller's unique behavior. This is accomplished by downloading the appropriate files from the server and implementing the appropriate actions to minimize overall costs.



# Silicon Wafer Sorting Machine

## Team JPJG

### Team Members:

- Philip Hunsberger
- Jack Durham
- James Artacho
- Garrett Gilcrease

### External Sponsors/Mentors:

- Willie Scales

### Internal Sponsors/Mentors:

- Dr. Robin Pottathuparambil
- Thomas Kanabay

### Abstract:

This project's goal is to refurbish a silicon wafer sorting machine by adding an Optical Character Recognition system that is capable of fully autonomously sorting up to 50 unsorted silicon wafers at a time. We are sponsored by a local Senior Field Engineer working with ATE Technologies, Inc., Willie Scales.

This machine is capable of moving, straightening, scanning, organizing, and storing wafers with minimal user input and interaction. It utilizes laser sensors, vacuum and air pressure manipulators, and electronic drill and motor pieces to complete its task, along with a sorting algorithm and user interface designed and implemented by our team at UNT.

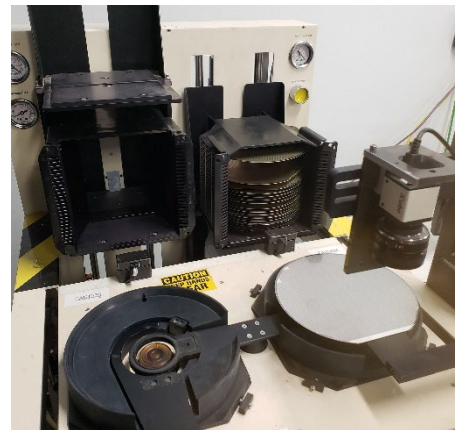

We would like to thank both Dr. Robin and Mr. Scales, along with the entire Computer Science and Engineering department for their help in obtaining this unique opportunity to work hands-on with the coding and embedded systems skillsets we have developed during our studies at UNT. Go Mean Green!

# MULTI-SENSOR CROWD FLOW VISUALIZER

## Team LyLAT

### Team Members:

- Aaron Kennemer
- Luke Hillard
- Luke Peltier
- Tony Phonglom

### External Sponsors/Mentors:

- xRez Lab

### Internal Sponsors/Mentors:

- Ruth West
- Thomas Kanabay
- Dr. Robin Pottathuparambil

### Abstract:

When a robotic/automated system “sees”, it does not perceive the same way as the human visual system does. This mismatch in human expectations of what a digital system perceives causes challenges in the integration of robotics/automated systems in human context; this problem originates from Bill Smart at Oregon State University. One such situation is in tracking the flow of individuals and groups in a crowd. This project, in collaboration with xRez Lab, seeks to create an innovative system that uses many sensors to track the flow of a crowd and with this tracking data visualize it in a form truer to how the system “sees” the crowd. The system itself with the visualization will help improve upon current crowd tracking methods and will use pre-existing vision recognition algorithms to verify their accuracy. The novel use of Virtual Reality being the medium of the visualization will help immerse those who put on a headset and help give insight on what the system “sees”. The non-VR related part of the system itself will help in the design of surveillance, crowd counting, and dynamic emergency escape systems.



Acknowledgements: Cindy Grimm, Bill Smart, and xRez Lab @ UNT

# Smart Canopy Lighting System

## Team W.A.C.C



### Team Members:

- Jeff Anderson
- Ben Cruse
- Eli Cruse
- Jared Westmoreland

### External Sponsors/Mentors:

- Intelativ

### Internal Sponsors/Mentors:

- Dr. Robin Pottathuparambil
- Thomas Kanabay

### Abstract:

The goal of this project is to make an Internet of Things (IoT) based Smart Canopy Lighting utilizing Wi-Fi instead of ethernet based communication thus lowering the cost of the product. This should capture data from the canopy light through the following sensors attached to the light: lux, temperature, camera, and NoIR camera. Then send the captured data through a central hub to be viewed from the outside world. The user should also be able to send commands from outside the network to perform tasks such as: turning the light on/off, adjusting light intensity, view a live stream of each light, and download recorded videos from each light. Videos should be stored within the cloud and on a local backup drive. Each Smart Canopy Light will utilize the lux sensor and change light intensity thus saving on energy costs.







# COMPUTER SCIENCE

# Git-Ripped



## Team Members:

- Brayden Berglund
- Zac Chambers
- Juan Orta
- Josh Robbins
- Jon Wendt

## External Sponsors/Mentors:

## Internal Sponsors/Mentors:

- Dr. Bill Buckles

## Abstract:

We are building an all-in-one weight-lifting web application that allows a user to log their workouts and visually see their progress over time and receive recommendations from the app itself – all within an attractive, user-friendly interface. With a flourishing fitness industry, there are a myriad of fitness applications on the market. Our end goal is to separate ourselves from competitors by giving users the option to create their own routines or use a customized routine that we generate for them, which has yet to be explored. This application will be beneficial to professional weightlifters, beginners and everything in between. By deployment, we plan on having this app available on both web and mobile platforms.



# ResQpet/Nexus

## Team Members:

- Dheepthi Somangili Babulal
- Julsan Magaju
- Mario Mendiola
- Makayla Zacarias

## External Sponsors/Mentors:

## Internal Sponsors/Mentors:

- Dr. Bill Buckles

## Abstract:

In the United States, 2.7 million dogs and cats are euthanized every year. Most animals are either dropped off at shelters or thrown on the streets due to reasonings out of their control. Reasonings such as a move, inadequate funds, or impatience for owning a pet. This is unfair to the animals. The number of euthanized and abandoned pets could be reduced if people had a way to share pets for adoption on a broad scale. ResQpet strives to resolve this issue by providing a platform shelters and everyday people can use to provide animals their forever homes.

ResQpet allows shelters and individuals to post animals up for adoption, while allowing potential adoptees to browse through the animals, pick their favorites, and adopt the pet, all through a mobile device. The app allows users to browse animals all across the country, increasing the likelihood of an animal being noticed and adopted. Animals are a gift to the world and deserve to find the best owner for them, ResQpet aims to help.



# Food Logging App - Team Spirit

## Team Members:

- Dania Chavez
- Greg Faaborg
- Oliver Banza
- Priyank Shah
- Pramisha Thapaliya

## External Sponsors/Mentors:

## Internal Sponsors/Mentors:

- Dr. Stephanie Ludi

## Abstract:

Rapid development in technology have encouraged the use of smartphones in health promotion research and practice. This smartphone application may provide a novel method of dietary assessment to capture real-time food intake and contextual factors surrounding eating occasions. The aim of this application is to evaluate the capability of a smartphone meal diary app to measure the health issues, either the users known issues or the issues which they are trying to figure out by logging and monitoring. This app will be the first step in helping users figure out or even over come the allergy or health issues that individual face in their everyday life.



# I Don't Know

## Team Members:

- Hoang Huynh
- Tuan Mai
- Gary Kau
- Horus Vidal

## External Sponsors/Mentors:

- None

## Internal Sponsors/Mentors:

- Dr. Bill Buckles

## Abstract:

This project will simulate and display the population of the prey and predators in the given environment based on hunger, speed, death and birth rate, etc. This can be used for educational purpose or to pre-determine result of the environment's result given by the users.

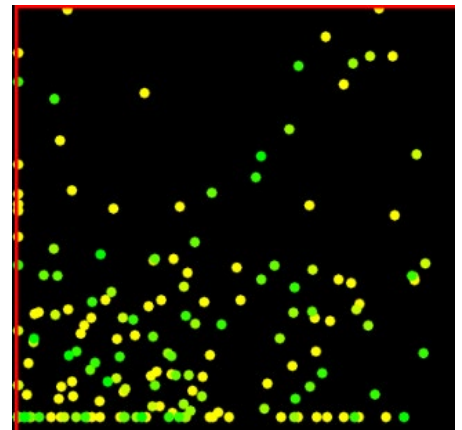



# Highway Fatalities Team Scrumbledor

## Team Members:

- Chhering Lama
- Fahim Sham
- Patrick Long
- Adam Williams

## External Sponsors/Mentors:

- N/A

## Internal Sponsors/Mentors:

- Dr. Bill Buckles

## Abstract:

In an effort to create easily accessible crash fatality data for researchers and educators, we have developed a web application which allows users to select from a variety of crash criteria and visualize the data in an easy-to-use interactive map and graph. A number of filter settings allow users to customize what information is displayed. This will help to monitor the crash area and take safety precautions in that area to reduce fatalities.

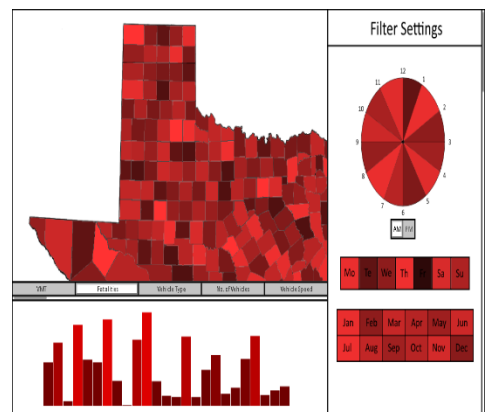



# UNT GradBook

## Team Members:

- Ethan Teel
- Kim Ashmore
- Andrew Clark
- Kevin Carroll

## External Sponsors/Mentors:

## Internal Sponsors/Mentors:

- Dr. Bill Buckles

## Abstract:

With a continuing influx of new graduate students each year at UNT and the rapid change of the area, a strong desire for readily relevant resources at the reach of your phone could go great distances in aiding these onboarding students.

Whether the information pertain to the area, UNT, or department, onboarding graduate students need a medium for multiple resources and shared experiences so they can focus on beginnings of their new journey

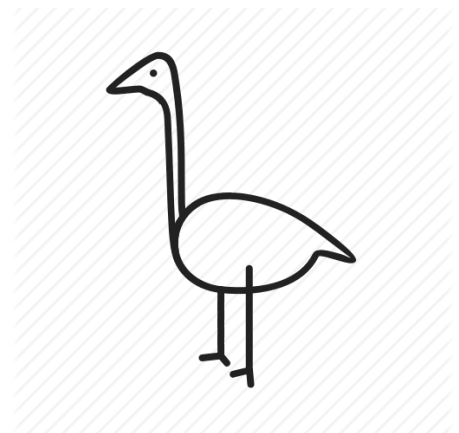



# Kidney Pirates Renal Patient Education App

## Team Members:

- Chris Cox
- Olivia Haynes
- Justin Hick
- Kevin Morales
- Jackson Pfeffer

## External Sponsors/Mentors:

- John Warth - DaVita

## Internal Sponsors/Mentors:

- Dr. Stephanie Ludi

## Abstract:

The End Stage Renal Disease Network of North Texas wishes to provide better education and accessibility for their treatment options to their patients. Most hospitals and dialysis centers rarely give enough information for people to understand their options and patients have very little knowledge of how their kidneys even work. This application will help educate users about their kidneys, renal disease, as well as give patients the resources to find nearby clinics and setting up appointments for their respective treatments.



A special thank you to Susan Haynes for stepping in as an external mentor to the group.



# Highway Fatalities Team 7

## Team Members:

- Steven Montes
- Fernando Martinez
- Thomas Vilchez

## External Sponsors/Mentors:

## Internal Sponsors/Mentors:

- Dr. Bill Buckles

## Abstract:

Texas is considered to be among one of the most dangerous states to be driving on a highway. To validate this statement we will compile information from all over Texas into an interactable map. This product to display most recent information about transportation fatalities and accidents based on user pre-requisites or filters.

Educators, researchers, or any person needing information will be able to have access to an easy-to-use product to learn more about their local area or any place in Texas.

Currently, there is no website or data source that provides this kind of service. Our solution will be the first of its own type.

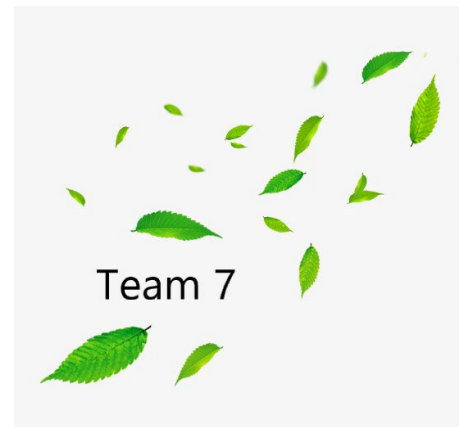

# Team Blue: Sponsor-Team Matchmaking Tool

# Match Me

## Team Members:

- Bohan Zhang
- Bobby Kim
- Abigail Rivera
- Theodore Tilleman
- Dillon McDonald

## External Sponsors/Mentors:

## Internal Sponsors/Mentors:

- Dr. Stephanie Ludi

## Abstract:

Project to match capstone teams with sponsors based on location, skill set, etc. Has various roles such as Sponsor or University. Matching can occur through suggestions or through browsing. The UI will support W3C Guidelines and will be accessible to disabled users.

# React.log

## Team TBD

### Team Members:

- Garrett Brumley
- Carlos Sibrian
- Muhammad Azam
- Alex Yu

### External Sponsors/Mentors:

### Internal Sponsors/Mentors:

- Dr. Stephanie Ludi

### Abstract:

Our app, React.log, is an online food reaction log to assist individuals in tracking medical issues they may experience due to consumption of certain foods. React.log takes advantage of the React.js library to offer a highly interactive UI to assist tracking your eating patterns and the option to generate reports based on your log entries. Whether you are having allergic symptoms, or just want to keep an eye on your general eating habits, React.log will help you watch your health.





# PhD Evaluation Tool Team Rockit

## Team Members:

- Jax Saunders
- Lee Robertson
- Jeremiah Dickens
- Chad Leito
- Triston Blessing

## External Sponsors/Mentors:

- Melanie Dewey

## Internal Sponsors/Mentors:

- Dr. Bill Buckles
- Dr. Stephanie Ludi

## Abstract:

Ph.D. students must provide an annual self-evaluation as part of their program and work towards their degree, as well as part of their standing in the department. The students' advisors must also provide feedback on their evaluations. We are currently working on a digital portal to replace the current entirely analog process. This would save significant amounts of time for the student, the advisors, and whoever else needs access to these documents. With our program, all of the self evaluations will be in one central, searchable, and archivable location.

Our program does not have a system like this, and we look forward to bringing this process into the twenty-first century.



# Parberryes Peasants

## Team Members:

- Adam Bell
- Anderson Adams
- Michael Cooper
- Erwin Sparks Jr.
- Denver Jayroe

## External Sponsors/Mentors:

## Internal Sponsors/Mentors:

- Dr. Stephanie Ludi

## Abstract:

Our group is attempting to design and create an application for android smartphones that allows students to take an AR tour of Discovery Park. This will allow students to become familiar with the places where they will be taking classes and areas of Discovery where they can obtain additional resources. We hope that this application will give students more incentive to learn about their campus while having fun in the process.

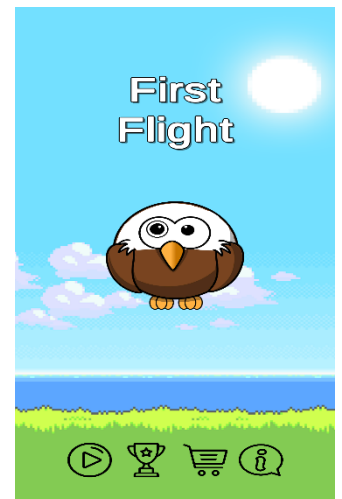



# Optimize Prime

## Team Members:

- Jesus Rodriguez
- Allison Goins
- Dan Shadel
- Chalet Shelton

## External Sponsors/Mentors:

- Dr. Nandika D'Souza

## Internal Sponsors/Mentors:

- Dr. Stephanie Ludi

## Abstract:

Incoming freshmen and transfer students often times struggle to determine what classes they still require in order to graduate. Our application fills the gap for students by providing an easy way for them to view their current college credits, as well as provide a way for them to see different options they have on their path to graduation.



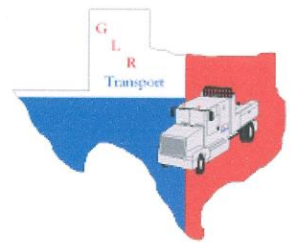

# No Java Please



## Team Members:

- Malik Fleming
- Sebastian King
- Brendan Nyambati
- Gustavo Espinosa
- Trenton Mitchell

## External Sponsors/Mentors:

- Wooley, Gerry & Wooley, Robert from GLR Transport

## Internal Sponsors/Mentors:

- N/A

## Abstract:

The business of transportation and logistics is growing faster than ever, and yet it does have much of a footing in the field of mobile technology.

In order to improve the logistics industry we are developing an application to simplify the documentation required when transporting goods. GLR transport performs the transportation of heavy goods and large freight, each job requires creating meticulous documents describing the contents, time constraints, contact details, pickup and drop-off locations as well as any government permits.

Each job currently requires filling out a Word document and e-mailing PDFs with permits. Even for a small company, these documents stack up quickly. It becomes easy to make mistakes, to type in the wrong destination to the GPS, to lose the number of the contact, to forget a job has been cancelled or approved, etc.

Our application will centralizes all of the documentation needed by GLR Transport. It automates functions such as calling the contact to verify orders, setting the GPS location and it even fills out timesheets for employees. The data entered is validated and all jobs status' are tracked, and all of the permits and employee information, including edits, timestamps of documents and history is easily accessible. Furthermore, the data is available offline for mobile users allowing it to be used on truck routes that have poor or no phone signal.





# Nicole & The Boyz: Meet Me Halfway

## Team Members:

- Alexander Alfonso
- Filmon Belay
- Mason Hobbs
- Preston Mitchell
- Nicole Russo

## External Sponsors/Mentors:

## Internal Sponsors/Mentors:

- Dr. Stephanie Ludi

## Abstract:

The purpose of this system is to create an application that will safely allow two people to find a safe meeting place, such as a police station, between them. This system can be useful in many scenarios where you need to meet someone - be it relatives on a family vacation or to exchange custody of items. This can be especially useful if you find yourself in an unfamiliar area.





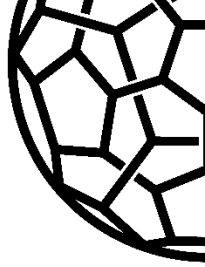

# Nice For What | Stats Coach

## Team Members:

- Richard Miles
- Cole Bush
- George Raheb
- Adam Boyer
- Kristin Carden

## External Sponsors/Mentors:

- Miles Systems, LLC

## Internal Sponsors/Mentors:

- Bill Buckles
- Mark Thompson
- David Keathly

## Abstract:

<https://Stats.Coach/> was a product needed by a team members parental unit. The original goal was to reduce the amount of paper score cards used by high school student athletes weekly. Throughout the UNT experience, something more quickly came into existence. CarbonPHP is a minimalist PHP 7.2, a scripting language written in C and rated faster than Python, framework designed to complete this goal as well as generally being sufficient for most web application backends. The most important structural note would be the entity system with **MySQL**. An **Entity system**, common in game programming, is a simplistic way to represent all information uniformly in an equally important graph. Thus, being analytically similar to an unweighted graph. The proposed improvement, which is seemingly very uncommon in web-applications is to centralize the Primary Key database. Moreover, the majority of tables in the database will have a centralized schema that only contains primary and foreign keys references in a tuple structure. In the visualization to the right you may notice the processor like logical information flow this also mimics. This objective flow allows two system critical features: Every table or entity is allowed to extend every other table. When an entity needs to be deleted all sub references will be cascade-deleted, a built-in MySQL feature, without additional programming needed. Simplistically said, this allows photos on comments, comments on photos, likes on either, ect... and any combination of the sort.

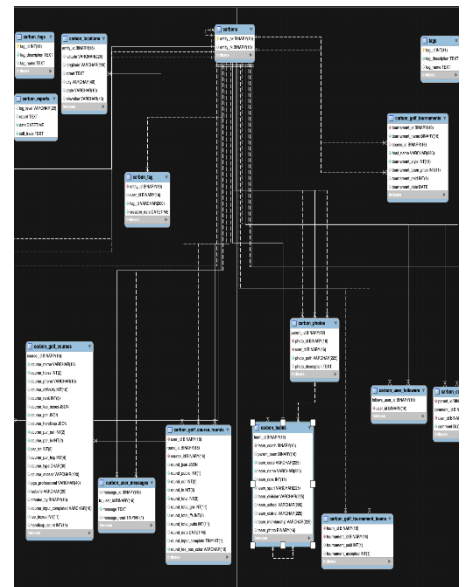

Entity  
Relationship  
Diagram

Most importantly Google Fu and Github. Then comes the Grand Master Thompson for his socket lecture and David Keathly for his go-for-it mentality. Finally thanks to Bill Buckles for letting us do us.



# Meet Me Halfway

## MAARK-5

### Team Members:

- Miranda Bigby
- Amy Raney
- Kaytlin Lafluer
- Abdullah Mumtaz
- Robin Rajan

### External Sponsors/Mentors:

### Internal Sponsors/Mentors:

- Dr. Stephanie Ludi

### Abstract:

Meet me Halfway is an Android application intended to help users find a destination at the halfway point between two entered addresses. This application may only have one broad functionality but can be used by a wide variety of users for many different scenarios, including but not limited to; custody exchanges, business transactions, or simply meeting up with a friend who lives far away.

While not a new concept, the market lacks a well made and refined application that provides the functionalities Meet Me Halfway will contain.

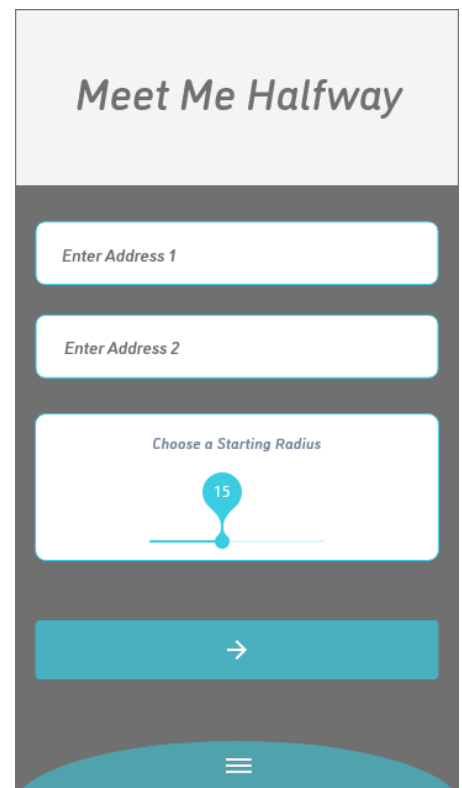



# Logica Aquilae

## Models of Predators and Prey

### Team Members:

- Gerardo De La Maza
- Logan Kuhn
- William Middlemiss-Kurtz
- Aashish Pandey
- Jesse Pierce

### External Sponsors/Mentors:

- N/A

### Internal Sponsors/Mentors:

- Dr. Bill Buckles

### Abstract:

Predator and prey population simulation using user inputted values. The user is directed to input initial populations for the predators and prey. They are directed to input both birth and death rates for both the predator and prey populations. Time is divided into generations with the population calculated multiple times per generation to improve accuracy. The population is displayed as a graph of both populations with the population on the vertical axis and the generations on the horizontal axis.

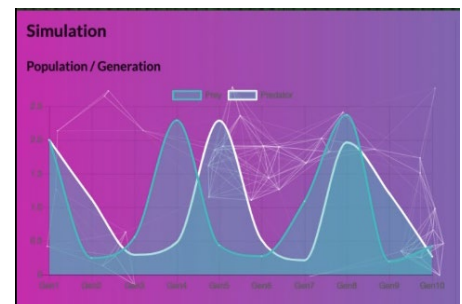

# Dungeons & Dragons All-in-one App By Homeschool Valedictorian

## Team Members:

- Adrian Lacour
- Brad Dennis
- Damien Wiggins
- Geoffrey Plasterr
- Trenton Blackburn

## External Sponsors/Mentors:

## Internal Sponsors/Mentors:

- Dr. Bill Buckles

## Abstract:

The goal of the Dungeons & Dragons All-in-one App is to make a simple and straightforward resource for all standard Dungeons & Dragons 5th edition material. Dungeons & Dragons can be a complex and confusing hobby to get into. The Dungeons & Dragons All-in-one App was created to be intuitive so that getting into Dungeons & Dragons is simple. This is done by having all resources available to players and providing an easy way to manage player's characters.



Thanks to Wizards of The Coast for making Dungeons & Dragons

# plateGuard Heavy Machinery

## Team Members:

- Michael Nutt
- Nathan Burgess

## External Sponsors/Mentors:

## Internal Sponsors/Mentors:

- Dr. Qing Yang

## Abstract:

In today's world there are cameras everywhere with little regard for the security of the privacy information gathered by those cameras. In many states police forces are using Automatic License Plate Reader (ALPR) cameras to record and catalog license plates in specified areas, often using lax security practices such as cameras that are connected using default passwords and are easily accessible over the internet.

plateGuard is a solution to these issues by working on both the embedded camera system and on a centralized server, first encrypting the entire video before transmission so cameras that are compromised still have the video secured and then encrypting just the plate area of the video once it has been transmitted to the server so the footage can be reviewed and individual license plates searched for and revealed.



# Meet Me Halfway

## Team Drop Table Students

### Team Members:

- Justin Muskopf
- Fischer Davis
- Matt Floyd
- Jaqob Montes
- Solomon Anowey

### External Sponsors/Mentors:

### Internal Sponsors/Mentors:

- Stephanie Ludi

### Abstract:

Sometimes two people need to meet at a halfway point in order to meet up so that neither party has to drive more than the other. There can be a variety of reasons for this such as meeting up with relatives as part of a trip or a custody exchange. This app will help 2 parties find the halfway point between them so that they can meet at a place of business, police station or some other establishment (as opposed to the middle of the road somewhere). The app can give the address of the location, as well as directions if desired.





# WakeyWakey

## Team Members:

- Shawn Lutch
- Chelsea Greer
- Richard Kriesman
- Cody Kyrk
- Miika Raina

## External Sponsors/Mentors:

- N/A

## Internal Sponsors/Mentors:

- Dr. Stephanie Ludi

## Abstract:

Conventional alarm systems provide few alarm customization options and use jarring noises that may startle small children. These systems can be reconfigured by children, whether accidentally or intentionally, which results in unintended behavior. Parents and guardians have little control over options such as alarm type, customization, and sleep scheduling.

WakeyWakey is a child-focused, guardian-managed alarm clock app for iOS and Android. Guardians create weekly *schedules*, each with a set of daily alarms. Each alarm has a time for a child to go to bed, wake up, and get out of bed. Alarms are highly customizable, with child-friendly avatars and sounds, color changes, and configurable snooze functionality. Settings are protected by a passcode to avoid unintentional changes.

WakeyWakey provides guardians the means of enforcing a more rigid – yet gentle and friendly – weekly sleep schedule for their children.



# Breakpoint — 9-1-1 Emergency Calling Simulator

## Team Members:

- Agustin Vallejo
- Alexander Perkovich
- Dakota Lambert
- Zachary Ferris

## External Sponsors/Mentors:

- North Central Texas Emergency Communications District (NCT9-1-1)

## Internal Sponsors/Mentors:

- Dr. Bill Buckles
- Dr. Stephanie Ludi

## Abstract:

Currently, the nation's best is learning how to handle an emergency using outdated technology. We aimed to modernize the emergency learning environment by developing a native solution on the Android platform to work on smart phones.

The application allows students to practice dialing and speaking to a 9-1-1 operator (the teacher) in a controlled environment.

With the 9-1-1 Emergency Simulator, parents and teachers can rest easy knowing that their children will be prepared for any situation that involves dialing 9-1-1.

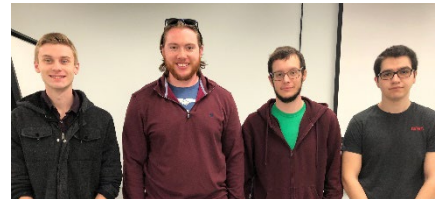

We would like to thank Amelia Mueller, the 9-1-1 Communications Coordinator, for all of her help through the development of the application.





# VIPER Text Editor – Bits and Pieces

## Team Members:

- Jose Duarte
- Stephen Lederer
- Dan Merlino
- Travis Pete

## External Sponsors/Mentors:

## Internal Sponsors/Mentors:

- Dr. Stephanie Ludi

## Abstract:

The Viper Text Editor was designed to aid visually impaired programmers with writing code for Lego EV3 Mindstorms Kit using the Python programming language. The editor will have user accessibility options such as bookmarking, speech-to-text, and screen-reader compatibility to facilitate a more streamlined user interaction for programming. Additionally, the editor will have more common features such as, font size and color options, line numbering, debugging, etc. This project is innovative because it brings together a lot of the existing tools for the visually impaired into one lightweight application.





# INFORMATION TECHNOLOGY



# CSE Advising Office Kiosk Technocrats

## Team Members:

- Alex Garnica
- Luis Plascencia
- Jared Quintana
- Jason Waites

## External Sponsors/Mentors:

- N/A

## Internal Sponsors/Mentors:

- Dr. David Keathly
- Melanie Dewey
- University of North Texas

## Abstract:

The purpose of the CSE kiosk is to provide student visitors with help on various topics. It saves time for both the student, who can get help immediately, and the staff, who are only notified when they can help a student.

The main functions of the kiosk are to display information, email information to the student, or send a notification to a staff member.



# Team Tech

## Team Members:

- Michael Dennis
- Nadia Kanwal Khan
- Adan Contreras
- Buchi Diai
- Leiton King

## External Sponsors/Mentors:

- Justin Dews

## Internal Sponsors/Mentors:

- Dr. David Keathly

## Abstract:

Our team, TeamTech, is Developing a solution to integrate multiple administration systems into a single web application, focusing on technician productivity and ease of use. The plan is to use APIs to display, record, and manage data from ConnectWise, Office 365 Admin.

The Client, TechVera, uses a program called ConnectWise to manage 75% of their business. It is slow, cumbersome, and deeply rooted in the entire business. TechVera is growing and is looking for a way to maximize the productivity of their engineers by spending less time navigating through a UI, and more time solving their client's problems.

Our team's goal is to eliminate the need to use ConnectWise & 365 Admin for Tier 1 help desk technicians.





# On Task

## Team Members:

- Andrew Adkins
- Peter Neal
- Terrance Jackson
- Brett Piatek

## External Sponsors/Mentors:

- Diana Bergeman
- Dr. Barrett Bryant
- Jim Halpert

## Internal Sponsors/Mentors:

- Dr. David Keathly

## Abstract:

OnTask is a task management / shared planner web application built to create, sort, and manage tasks within an office environment. OnTask is fast and efficient with an emphasis on instant reactivity to task changes and progress. OnTask was created by the IT Capstone group "Terrence Jackson and the TJs" for the Faculty and Staff of the CSE Department at UNT.

OnTask manages tasks with the robustness of a ticketing system with the ease of access of a planner. Tasks can be assigned to individuals or groups simultaneously, automatically tracks user statistics, prioritizes tasks using built-in business logic, and integrates with already-in-place UNT resources.

OnTask is built on Meteor, a full-stack web development framework that leverages real-time distributed data processing, that abstracts websocket programming to be as simple as "define a collection, publish a collection on the server, subscribe to the collection on the client, and automatically update the DOM when changes to the collection are made". Using native Meteor functionality hand-built delivery logic, OnTask is a powerful, efficient tool for creating and accomplishing tasks.





# W3 Digital Vision Team Eventer Support

## Team Members:

- Timothy Clark
- Daniel Mandujano
- Kevin Spracklen
- Marshall Montgomery

## External Sponsors/Mentors:

- Bryan Montgomery

## Internal Sponsors/Mentors:

- Dr. David Keathly

## Abstract:

W3 Event Specialists are an Austin based company providing event staffing services such as music venue security, stage building, and film set security. The company's current site serves to provide basic information about the company and its services and some links to information for contractors. The client believes that the site could be doing more for the company and wants to implement several changes to add functionality to the site for the company and all users. Ideas that the team explored for implementation include a calendar employees could log into to view and sign up for jobs, a service request page that prospective clients could use to request staffing, adjustments to the online employ application that allows information to flow more smoothly into paperwork, and adding mobile support for the site.





# Carnac, Reddit Trend Analyzer

## Team Members:

- Justin Stout
- Ezequiel Cepeda
- Vien Huynh
- William Quan

## External Sponsors/Mentors:

- Kyle Taylor, TechMill Denton

## Internal Sponsors/Mentors:

- Dr. David Keathly

## Abstract:

Carnac is an application that allows users to target specific subreddits or groups of subreddits to gather data about trending posts from reddit.com, and perform data analysis using natural language processing.

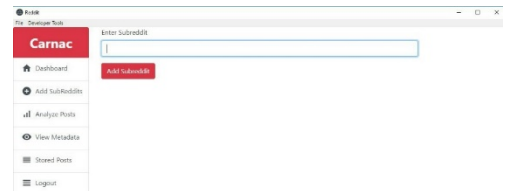

# Digital Signage System

## 4N1

### Team Members:

- Brandon Soo
- Venice Luong
- Jorge Mendoza
- Ghadeer Alqaisoum

### External Sponsors/Mentors:

- N/A

### Internal Sponsors/Mentors:

- Dr. David Keathly
- Thomas Kanabay

### Abstract:

The Computer Science Engineering department's [CSE] workers, who have offices, have issues communicating with their students. When the workers are not going to be in their offices for many reasons, they have to announce it to all students in the department which required that they write a note in 7 labs including their own offices. Moreover, the note should have a reason for not being in the office, change in lab hours, or office hours which cost time and effort especially if the workers need to change the notes daily.

The team 4N1 has come up with an idea to solve the problem that the workers in the CSE are facing by creating Digital Sign System for CSE Labs which is basically a messaging program that sends a message from one device to other multiple devices. Also, it will have the ability to preview time and date. The devices will be hanging on each of the lab's window. They will receive messages from the administrator's server side, and the students will only see the notes or the message that the workers want to deliver to the students.

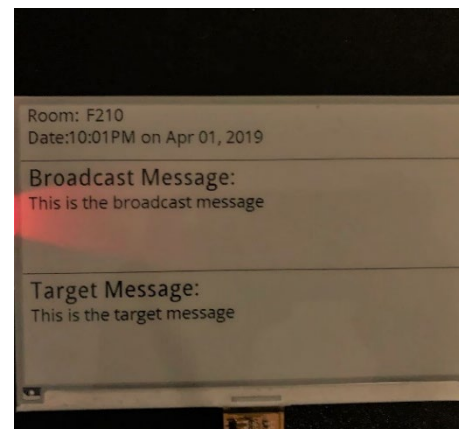





# CirclesU - Car Ramrod

## Team Members:

- Myles Edwards
- Keith Armstrong
- Corey Gendron
- Ryan Gibeault
- Kiefer Hardin

## External Sponsors/Mentors:

- Parker, Wallace
- Forerunner Creative, Inc.  
608 E. Hickory St., Suite 128, Denton, TX,  
76205

## Internal Sponsors/Mentors:

- David M. Keathly
- UNT Discovery Park  
3940 N Elm St, Denton, TX 76207  
Office: NTDP F202

## Abstract:

The "CirclesU" application is a mobile-based app that connects users to social groups based on their location within a geofencing location. These groups, or circles, can be created by users to share content exclusively with other people that join their groups, that is, if they have visited the required location to validate access to a particular circle. CirclesU is to be developed as a progressive mobile application, as to mediate the need of developing solely for iOS/Android. A stable Internet connection will be necessary for use of this application, as well as GPS capabilities. The use of Google Maps API will be a key component of the development for GPS and geofencing capabilities.



# Amba Pim Pim

## Team Members:

- Zach Scott
- John Cunningham
- John Nguyen
- Shelton Childress

## External Sponsors/Mentors:

- Isaac Zama

## Internal Sponsors/Mentors:

- Dr. Marty O'Neill

## Abstract:

Amba Pim Pim is a android taxi application that connects an able driver with a client that needs automobile transportation. The main thing that separates this transportation service from other taxi services it that it removes unnecessary traffic and clutters that taxi drivers create when trying to find a client. Our application helps by creating an interface between the client and driver to establish a relationship and route before the trip takes place. Aside from making the roads safer, our application gathers useful data from our users such as their routes so that infrastructure planners can use it in their decision in making transportation more accessible for all. The application is very simple to use, for the clients, after they have made an account all they would have to do is request a ride and fill out key information such as their location and destination.

Once that is done, a driver who is in the ready state will receive an incoming message that they will either accept or decline to take the passenger. If the driver accepts they will receive the client's request details and if they decline the application will send another client's request.



Department of  
**ELECTRICAL**  
**ENGINEERING**



# Machine Learning Application to Hydraulic Fracturing

## Team Members:

- Giovanni Tamez
- Aaron Colmenero
- Danytza Castillo
- Jorge Ayala

## External Sponsors/Mentors:

## Internal Sponsors/Mentors:

- Colleen P. Bailey, PhD

## Abstract:

Hydraulic fracturing has greatly impacted the oil and gas industry and is a large component of future oil production. Proper operation is dependent on supervisors monitoring data for signs of dangerous pressure spikes. Human error becomes a large factor in processing such a large amount of data in real time. The system proposed in our senior design project is able to read and interpret the data from a well in order to make accurate predictions on when potential pressure spikes will occur within the well, saving time and money on projects that are pushed to the limit.



# Acoustic Resonance Spectroscopy

## Team Members:

- Art Depoian
- Caleb Jackson
- Daniel Usher

## External Sponsors/Mentors:

- Dr. Oscar Garcia PE  
-Founding Dean, UNT College of Engineering

## Internal Sponsors/Mentors:

- Dr. Tao Yang  
-Faculty advisor

## Abstract:

This project establishes a novel and low cost approach to analyze the contents of a given vessel in a non-invasive manner. The use of commonly available devices to carry out the procedure, along with open source software for processing, created a novel approach to the question at hand. Drawing upon known research in the acoustic spectrum at ultra-sonic levels, it was proposed that similar techniques might be possible in the audible spectrum. The device works by flooding the vessel with acoustic pressure waves at a given frequency, thereby creating resonance, which is sensed through a phonograph cartridge in contact with the exterior of the vessel. The resulting analog wave is sampled by the sound card on a common computer. Once in the digital domain, the signal is passed through signal processing algorithms that find the FFT(Fast Fourier Transform) and the most significant peaks of the FFT, which are then logged and stored for further processing. Depending on the need, the control algorithm might call for additional testing to create greater resolution. At the conclusion of testing, the developed device makes a final decision as to the current state of the vessel. The device has been built to train and learn eventually expand the possible solution set through a machine learning control algorithm.



. Thank you, Prof. Colleen Bailey PhD



NECTAR

# Rosie: Smart Trash and Waste System

## Team Members:

- Jenna Chesley
- Brandon Costello
- Taylor Hyde
- Brian Kaplan
- Brian Morgan

## External Sponsors/Mentors:

- Nectar Agriculture

## Internal Sponsors/Mentors:

- Dr. Xinrong Li

## Abstract:

After studying the recent California legislation which enforces regulation on business waste management procedures, our project team, sponsored by Nectar Agriculture, developed a prototype system for a smart IoT trash can product called Rosie. The system detects when a trash bag needs to be changed in heavy-traffic areas by monitoring the weight and volume of the bag contents. When any bag needs to be changed, the product will notify the administrator via a push notification using the MQTT messaging protocol. Our IoT device will allow companies to generate reports on their waste producing patterns to ensure compliance with the government regularization and also to implement schedule optimization of their custodial staff. Other features of this prototype include a motorized, motion-activated lid and a visual display. It also monitors odor emissions for future product development. This product is ideal for airports, casinos, event centers and large corporation cafeterias and it will make it easier for companies to demonstrate compliance to the new government regulation on the business waste management procedures.



# Machine Learning Expansion on Smart Microgrid and Energy Management

## Team Members:

- Cameron, Falgoust
- Lauren, Guidry
- Farjana, Sumaiya
- Erin, Mears

## External Sponsors/Mentors:

## Internal Sponsors/Mentors:

- Dr. Tao Yang, College of Engineering

## Abstract:

The current smart microgrid is a very centralized network, with a master controller operating for the slave nodes to shed any loads if needed. However, a centralized network can be risky. In the event that the main controller is compromised, then the grid safety nets are eradicated. Our solution was to decentralize the network by implementing a machine learning algorithm to grant autonomy to the slave nodes. This allows the slave nodes to continue the previously established load shedding function, that sheds the lowest priority load for a limited power supply. This process maintains an important safety measure to the smart microgrid, keeping the highest priority loads in power for longer. This extra precaution could be imperative for hospital microgrids, for example, in the event of a power outage, keeping the ICUs up longer than the waiting area. Machine learning is still a relatively new process, but especially so in the realm of smart grids. Our work provides a unique approach to grid security, predicting how the grid will operate under a finite amount of power.



We would like to acknowledge Kelvin Darden for his help, and for his thesis we are using a basis.



## Smart Parking System

### Team Members:

- Enrique Reynoso
- Nahra Mejia
- Rafael Mora
- Arturo Sifuentes

### External Sponsors/Mentors:

- N/A

### Internal Sponsors/Mentors:

- Dr. Parthasarathy Guturu

### Abstract:

We are developing a high-end website that enables users to find parking in a matter of seconds. The website will be called SPS which stands for Smart Parking System and will be available for any student connected to the UNT's network. This is needed because finding a parking spot in time for class is a major problem for students who are unable to get to campus early or work. The parking lot will have sensors placed on the top and middle to guarantee accurate readings. The state of these sensors are transmitted to the Arduino UNO microcontroller. From there, the data is transmitted to a Raspberry Pi where the information is then stored in a MySQL database which our website will read from. The website will use the stored information to display the availability of the parking lot using a friendly Graphic User Interface (GUI). In conclusion, the SPS will allow users to visually locate the available spaces via LED indicators and a website which will provide the exact locations of those spaces.



I will like to take the opportunity to thank my parents for all the love and support.



# Solar Powered Tiny Home on Wheels



## Team Members:

- Julie Fox
- Alvin Abraham

## External Sponsors/Mentors:

- N/A

## Internal Sponsors/Mentors:

- Dr. Miguel Acevedo

## Abstract:

Abstract—The growth in solar power technology in recent years has made it more affordable and approachable for use in the modern household. This growth, coupled with the desire to live a more mindful, adventurous lifestyle and understanding the need for sustainable power solutions inspired this project. Our solar powered tiny home on wheels is a small-scale, off grid system that has full capability of powering our home both on and off the road. It uses solar energy provided by a 600W solar array to maintain a 200Ah capacity battery bank and can provide 2000W of continuous AC power. The system also incorporates an Arduino based power monitor to track our consumption. Once testing of the system's operability through all seasons is complete, our design can give other tiny home owners, RV owners, or smaller home owners the option to power their homes with solar power using a similar design and approach. Our overall goal is to shed light on alternative living options and living a more sustainable lifestyle through renewable power solutions.



Special thanks to Dr. Miguel Acevedo for helping guide us through the process of bringing this project to life.



# Gecorocode

(Gesture Controlled Rover  
with Collision Detection)

## Team Members:

- Andrew Napieraj
- Ayodele Ojo
- Robert Welch

## External Sponsors/Mentors:

- N/A

## Internal Sponsors/Mentors:

- Dr. Xinrong Li

## Abstract:

We are building a Gesture Controlled Rover with Collision Detection, or what we call Gecorocode. Gecorocode has three major components: detecting gestures from the user, using these instructions to move the rover, and reading the rover's surroundings to determine and prevent future collisions. In order to successfully incorporate these components, we will utilize the communicative abilities of the ESP32 microprocessor, which can handle either Bluetooth or Wi-Fi communications.

Gecorocode has many different possible uses. For our project, we are focused on its gesture control component in order to design a user friendly, gesture controlled rover in a market where most similar products are somewhat non-user friendly. This is due to their difficult to control nature, where instructing the product to move in specific directions becomes a challenge to comfortably control. We've designed a method to help with this issue. Essentially, we created a parabola, where the y-axis represents intensity of acceleration and the x-axis represents the hand position. This allows a smoother acceleration from a stop and a smoother deceleration from "full throttle." On top of this, we utilize an optimized programming strategy in order to decrease processing time and increase product responsiveness.



Department of  
**ENGINEERING**  
**TECHNOLOGY**



# CONSTRUCTION ENGINEERING TECHNOLOGY



# Wildlife 10

## Team Members:

- Dylan Pelt
- Zamira Escamilla
- Omar Maraqa
- Joe Scroggins
- Christian Pineda

## External Sponsors/Mentors:

- Hector Rivera
- Mike Van-Slyke

## Internal Sponsors/Mentors:

- Dr. Zhenhua Huang

## Abstract:

One Team Building Co. has been tasked with overseeing the construction of a 524,460 sq. ft. warehouse with approximately 50-70 docks, located at the intersection of Belt Line Rd. and I-30 in Grand Prairie, TX. The scope of work focuses on preparing the site, underground utilities, foundation, paving, erecting tilt walls and the metal roof. Our team's objective is to prepare the documentation for the project regarding the schedule, budget, safety plan, risks analysis and logistics.

This project is a tenant build out, which simply means Ridgemont is only responsible for building the warehouse shell. At which point, the owner representative will determine what interior finishes they require for their warehouse, and will then choose a subcontractor to finish the interior.



# North Texas Construction

## Team Members:

- Erica Rose
- Eduardo Aguirre
- Michael Williams
- Omar Khodr
- Alex Mulcahey

## External Sponsors/Mentors:

- **Sponsor:** Vaughn Construction
- **Mentor:** Andrew Thompson, Adam Perkins

## Internal Sponsors/Mentors:

- **Faculty Advisor:**
- Aloysius Attah, P.E.

## Abstract:

Our senior design project is the “University of North Texas Joe Greene Residence Hall” located on the main campus of University of North Texas (UNT) at 800 Avenue A and Building #0169, 1417 Maple St. Denton, Texas.

Based on the need established in the 2013 Campus Master Plan, the University of North Texas will construct a new residence hall to provide 1000 beds and the corresponding support areas. The 1,000 beds may be constructed in multiple facilities and locations in accordance to the UNT Campus Master Plan. It is anticipated that the construction will be in multiples phases with the initial phase constructing approximately 500 beds. Emphasis is given to providing a living-learning type of environment with ample study and shared common spaces throughout the building. Additionally, there will be a Tourist Center component, as well as housing and dining administration offices. A new central plant will be located in the existing Kerr Hall mechanical room along with a new cooling tower.

Our project team planned and performed management analysis of the Joe Greene Residence Hall located at the University of North Texas. The sections covered will include: Logistics and Layout, Budget, Schedule, Sustainability, Value Analysis, Risk Assessment, Safety Plan, Business Plan, and Computer Modeling program such as BIM.



# Jaguar | Landrover/R&R Construction

## Team Members:

- Ricky Evans
- Brendin George
- Ryan Condra
- Justin Tolle

## External Sponsors/Mentors:

- Bryan Bennett, Senior PM Ridgemont
- Blake Templeton, Asst. PM Ridgemont

## Internal Sponsors/Mentors:

- Dr. Saman Rashidian

## Abstract:

We have been given the job under Ridgemont to help build the new addition for the Jaguar | Land Rover dealership in Frisco, Tx. There are two phases in the project, as R&R Construction, we are in charge of Phase II.

We will be in charge of the scheduling, ordering of materials, and construction from above grade work all the way up until the roof is on and waterproofing has been completed. The new addition will consist of an expansion on the existing showroom, a service room, service drive and a new car delivery room.

Our milestones will cover the following topics: Logistics/Layout, Budget Outline, Rough Schedule, Sustainability/Green Review, Value Analysis, Risk Assessment and Business Plan.



# N South Fwy Bridge Value Engineering for the TRE Trinity River Bridge Project

## Team Members:

- Cole Hyun
- Jett DeRiso
- Matthew Kimmich
- Blake Kuecker

## External Sponsors/Mentors:

- Lee Pelton  
Austin Bridge and Road  
Assistant Project Manager

## Internal Sponsors/Mentors:

- Dr. Saman Rashidian

## Abstract:

Our senior design capstone project is to value engineer the N South Fwy bridge (bridge 612.20) of Austin Bridge & Road's TRE Trinity River Bridge Project job. The full project scope consists of adding a second track over a three-quarter mile distance, constructing 5 new bridges (including bridge 612.20), and refurbishing the steel truss bridge over the Trinity River.

Due to the original plan for bridge 612.20 not being efficient, our sponsor, Lee Pelton, asked for us to value engineer the bridge to save time and money as well as allow the Trinity River Express to run sooner than originally projected. Using our knowledge and experience, with generous aid from our mentor, we will join together as G4 Construction Co. to develop a schedule, budget, business plan, risk analysis, and value analysis as a general contractor in order to value engineer bridge 612.20.

Our design consists of two single track 125 foot span bridges to replace the existing single track 42 foot span bridge. We will use two 600 ton cranes to hoist each fully assembled new bridge into position. We anticipate our design to cut weeks of construction time off of the original schedule.

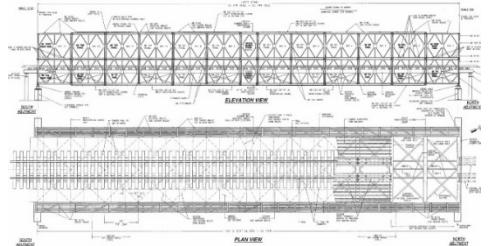





# ARVIN HILL ROAD – ROADWAY & DRAINAGE IMPROVEMENTS

## Team Members:

- Thamer Alameer
- Logan Vidrine
- Alton Cheek
- Ebiye Ofongo

## External Sponsors/Mentors:

- DENTON COUNTY/ Fred Ehler, P.E.

## Internal Sponsors/Mentors:

- Aloysius Attah, P.E.

## Abstract:

Arvin Hill Road Roadway & Drainage Improvements. The project will take a place at Arvin Hill Road, Aubrey, TX. On Tuesday, December 18, 2018, Denton county accepted Ed Bell Construction Company's bid at \$3,761,323.64. The project should be completed within 400 consecutive calendar days. This project consists of the reconstruction of Arvin Hill Road from US 377 to Red Mesa Trail including roadway, drainage improvements and all extra work related to the project.

Due to changing in weather, heavy rain and low maintenance, Arvin Hill road is damaged and it needs to be rebuilt to serve the people who live in that area. The project will improve the quality of the street, utility supply and the drainage system. Also, it will connect Arvin Hill to US 377 in different way for a better safety measurements. The project will insure that the people who live in that area will have access to a better public services.

Our main objective is to implement a team-based approach to construction projects. prepare documentation regarding the major works on the project. The documentation will include: Logistics, Layout, Budget, Schedule, Sustainability, Value Analysis, Risk Assessment, Safety Plan, Business Plan, and Computer Modeling program such As AutoCAD.



# CNET Senior Design Capstone Eagle Construction

## Team Members:

- Zachary Hill
- Gerardo Martinez
- Sergio Florido
- Frank Robles

## External Sponsors/Mentors:

- MYCON General Contractors
- Justin Swaim

## Internal Sponsors/Mentors:

- Dr. Cheng Yu

## Abstract:

Our team's senior design project is the Justice Plaza Retail/Office Buildings and is located at 1405 East McKinney Street in Denton Tx with a lot size of 4.57 acres. Justice Plaza is a design bid build project with two phases and our group will be doing our project over phase one. Phase one consists of two retail/office buildings, excavation and construction for a detention pond, and installing the sanitary sewer, storm sewer, and domestic water lines to tie into the existing underground utility system.

The first building is 12,190 SF and building two totals out to be 13,270 SF. The two buildings are both wood framed buildings and will have a stone and stucco exterior finish. MYCON is just constructing the shell of the building once the owner has leased out his building then the people who leased them will hire their own contractors to do the interior finish out. The detention pond will be surrounded by a redi-rock retaining wall with a 6" clay liner to seal the bottom of the pond. The detention pond has the 36" RCP inflow coming in from the North to catch all the runoff water from the back of the property and has an outfall structure that lets the storm water continue to flow through the system.

Our team will be constructing a report for Justice Plaza that will include; logistics and layout, budget, schedule, sustainability, value analysis, risk assessment, safety plan, business plan. Our team of four plan on working together using the tools and skills we have learned over our time in the CNET program at the University of North Texas.



# Knockout Construction

## Team Members:

- Tyler Roberts
- Aaron Scott
- Quinn Shoop
- Cameron Craig

## External Sponsors/Mentors:

- Breck Landry

## Internal Sponsors/Mentors:

- Dr. Zhenhua Huang

## Abstract:

Our senior design project is the Gaylord II apartment complex located in Frisco, T.X. at the corner of Gaylord Parkway and Ohio St. The apartment complex will consist of a parking garage and 254 multifamily units. The 1<sup>st</sup> floor will consist of a clubhouse, 56 units, and a fitness center. The 2<sup>nd</sup> floor will have 66 units. The 3<sup>rd</sup> floor will have 69 units and the 4<sup>th</sup> floor will have 69 units as well. There will be 2 swimming pools, one will be in the court yard and the second one will be on the top of the parking garage.

Our team analyzed the design and management aspects of the project. There are 7 key aspects within design and management that we focused on for the project. These 7 aspects are : Logistics, Site layout plan, Budget, Schedule, Sustainability, Value analysis, Risk assessment, Safety plan, Business plan, and a Computer modeling. Our team created documentation pertaining to each individual aspects that will reflect the work we have completed for this project.





# UNT Dining Hall

## Very Good Building and Development Co.

### Team Members:

- Kevin Copher
- Nathan Butcher
- Manuel Delacruz-Pena
- Juan Garcia

### External Sponsors/Mentors:

- Robert Will – Preconstruction Manager, Rogers-O’Brien Construction

### Internal Sponsors/Mentors:

- Dr. Cheng Yu

### Abstract:

Our senior design project is the UNT Dining Hall located in Denton, Texas. Our project consists of the new dining facility at the address of 1416 Maple Street, Denton, TX 76201. The dining facility will be approximately 36,000 gross square feet, and be able to support approximately 700 person seating capacity. Dining room(s), associated kitchen, preparation, storage, dishwashing, and all other necessary support areas of a modern dining facility shall be included. The idea of the new Dining Hall is to create a great dining experience that would attract new students, and retain existing students. The new Dining Hall will give the students to be able to customize their meals, and experiences while being able to visually see the food preparation.

Our project team is tasked with creating a project report, project presentation, and poster board. The project report will cover the following section: Business Plan, Logistics and Site Layout, Risk Assessment, Safety Plan, Value Analysis, Sustainability, Budget, Schedule, and a Computer Modeling program such as BIM.



# Charles Schwab Westlake Campus: DFW-2 Office Building

## Team Members:

- Omar Cereceres
- Tomas Becerra
- Ruben Garza
- Luis Cobos Montes

## External Sponsors/Mentors:

- TDIndustries
- Brent Hawley
- Dan Weir
- Ben Berard

## Internal Sponsors/Mentors:

- Dr. Cheng Yu

## Abstract:

Our team has been assigned the Charles Schwab DFW-2 Corporate Campus building located on the southeast corner of State Highway 114 and State Highway 170. The DFW-2 building will be one of the four buildings part of the Charles Schwab DFW Corporate Campus. The project located on the 69 acre site will support 3,000+ employees and include approximately 1.4 million square feet in floor area.

The scope of work includes all the Mechanical and Plumbing (MEP) components for the DFW-2, 194,045 SF 4 story building. The 194,045 SF of the floor area will include offices, elevators, lounges, large video conference rooms, open office space, restrooms, storage spaces, lobby areas and reception areas.

Global Construction is tasked with analyzing and understanding the project, in order to accomplish this our group will address and analyze different categories such as: Logistics and Layout, Budget, Schedule, Sustainability, Value Analysis, Risk Assessment, Safety Plan, Business Plan, and Computer Model.



# Energy Square One Remodel

## North Texas Contracting

### Team Members:

- Bobbie Daniels
- Rhett Butler
- Josh Fleming
- Sebastian Gatewood

### External Sponsors/Mentors:

- Evan McKee
- The Whiting-Turner Contracting Company

### Internal Sponsors/Mentors:

- Dr. Zhenhua Huang

### Abstract:

Our team was tasked with creating a project that aligns with the Energy Square Redevelopment project located in Dallas, Texas. This project includes the removal of tenant space, remodeling, and redeveloping of the first floor of an office tower building. This project report will consist of details on the construction of the first floor. The 25,000 square foot scope of work consists of demolishing and removing current tenant space, adding new exit doors and stairs, remodeling for a new fitness center, and obtaining a new certificate of occupancy.

Much of the scope for this project will lie in the addition of a 10,331 square foot new fitness center. This fitness center will include locker rooms, a fitness studio, a laundry room, and a massage room. The new 1,700 square foot terrace level will be located above the fitness level. There, tenants will have the option to enjoy their lunch and other social activities.

Other scopes involve the addition of 3 conference centers and the relocation of a Deli. The last scope includes the remodel of the bathrooms and the office building mail room. Much of the work will be done on the first floor of the office building but other work will be performed on the second floor to coordinate with all the remodel happening for the fitness center.

*We would like to personally thank Dr. Attah for his continued guidance, Bobby Daniels for constant support, and Evan Mckee along with the Whiting-Turner team for giving us this opportunity.*





# The Colony Firehouse No.4

## AP Construction

### Team Members:

- James Elliott, Aubree Rowley, Cody Western, and Casey Winsor

### External Sponsors/Mentors:

- Steele & Freeman, Inc.

Brian Hennington, Project Manager (CMAR)

### Internal Sponsors/Mentors:

- Aloysius Attah, P.E.

### Abstract:

Our Senior Design project is a close partnership with Steele & Freeman in specifying, planning and performing management analysis during the Colony Firehouse construction project. The project is located on 3400 Plano Parkway In The Colony, TX approximately ¼ mile south of Texas 121 (Sam Rayburn Tollway). The work is composed of a single story Fire Station, including general construction, site development, HVAC, plumbing, electrical and fire sprinkler systems. The work of this contract for Fire Station No. 4 will be performed under multiple subcontracts with the Construction Manager at Risk. The Colony officials know that the city was in need of a new fire station, so they turned to Steele & Freeman to come up with a resolution to the cities problems. Fire Station No. 4 will be approximately 22,000 square feet with a total of 5 bays. The size of this Fire Station is larger in size to accommodate for the rapid growth of the area off of SH 121. Within the new Fire Station it will include all of the latest gear available as far as ventilation. Also including bi-fold doors for functionality as well as modern designs for the kitchen, as well as updated sleeping corridors for the firemen, as well as new training opportunities for the firemen. All of these updates to help prepare for future growth in the area.



Special thanks to the College of Engineering, along side the Department of Construction Engineering Technology, Steele & Freeman, The Colony, and The Colony Fire Department.



# **ELECTRICAL ENGINEERING TECHNOLOGY**





# Solar- Charged Atmospheric Particulate Matter Monitor

## Team Members:

- Jasson Paragas
- Estefano Mateos-Rivas
- Steven Clark

## External Sponsors/Mentors:

- N/A

## Internal Sponsors/Mentors:

- Dr. Elias Kougianos

## Abstract:

Our Atmospheric Particulate Matter Monitor, APMM for short, provides a safe and portable option for collecting PM2.5 information in its immediate surroundings. With the inclusion of a solar panel, battery, and charging circuit, our version of Butrón-Guillén's APMM will be able to provide enough energy, using solar power, to power itself without the need of a wall adapter. The new design includes a PM2.5 sensor that will give us readings of PM2.5 particles in the surrounding area instead of relying on data from miscellaneous websites. The design is compact enough to attach to a drone or robot to bring into a hazardous area safely, as well as display data through a phone app and LED matrix for ease of use and readability.





# Digital Spirit Level

## Team Members:

- Mohammed Almazroey
- Naif Alsarrani
- Shengtong “Rick” Wang

## External Sponsors/Mentors:

- N/A

## Internal Sponsors/Mentors:

- Dr. Elias Kougianos

## Abstract:

This project is a measurement tool designed to indicate whether a surface is horizontal or vertical, generally used by carpenters and construction workers. The advantages over the conventional design is to have an entirely remote readout and precise result of measurement. It measures the angle between itself and the surface, and the distance from the spirit level to any object within 4 meters. This project has a Bluetooth module that enables the user to connect it to a cellphone and receive data from the device and display data on our custom app. Solar panels are built in the device to charge the battery and allow power to pass when the battery is fully charged.



The original idea came from:

<https://howtomechatronics.com/tutorials/arduino/arduino-range-measurer-and-digital-spirit-level-project/>

# Sonar Speaking Stick

## Team Members:

- Ehinomen Edo
- Abdullah Albahrani
- Mahmood Aldamin

## External Sponsors/Mentors:

- N/A

## Internal Sponsors/Mentors:

- Dr. Elias Kougianos

## Abstract:

The speaking sonar stick is a device used by the visually impaired. The project can be packaged to make a distance sensing walking stick for the blind and visually impaired for navigating their course.

For a tactile feedback to be provided instantly, the relay outputs may activate small vibration devices. It consists of an ultrasonic cane for the user, an LCD readout display and a Raspberry Pi microcomputer which can monitor, administer and execute functions, at the same time and at a good speed.

The most innovative feature of the sonar stick is the GPS which helps the visually impaired to be tracked and also provides audible directions.

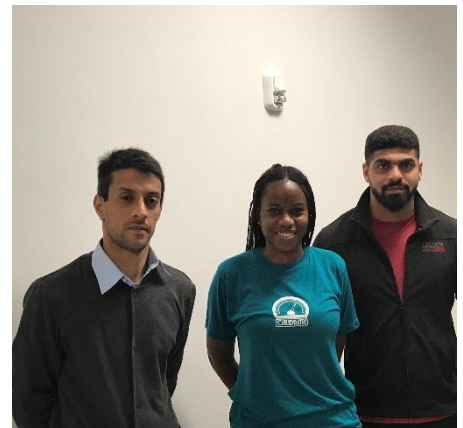



# Automotive Telemetry Project

## Team Members:

- Abdel-Qader, Omar
- Jeikowski, Kurt
- Maag, Nicholas
- Richmond, Jacob

## External Sponsors/Mentors:

- N/A

## Internal Sponsors/Mentors:

- Dr. Elias Kougianos

## Abstract:

Our project collects telemetry data from any vehicle and displays it to the driver while also transmitting that data for off system records. The data is collected from the On-Board-Diagnostic (OBD) system, a GPS and an accelerometer. The data is fed into a Raspberry Pi that runs the graphic to display the data on a touchscreen while wirelessly transmitting the data to an Internet of Things (IoT) system for later review.

Off-line analysis of the collected data is possible either at the car itself or from a laptop/desktop computer.





# **MECHANICAL ENGINEERING TECHNOLOGY**

# Aeromotive Technologies (Formula SAE Aerodynamics)



## Team Members:

- Kyle McDougal
- Byron Hameline
- Nick Luciano
- David Perry
- Jeb Owens

## External Sponsors/Mentors:

- Polaris Machinery Group
- Duna USA
- QA1
- SIEMENS
- Peterbilt
- Fastenal
- Solidworks
- Thermoforming Process Products

## Internal Sponsors/Mentors:

- Mean Green Racing (UNT Formula SAE)
- Dr. Maurizio Manzo
- Dr. Leticia Anaya

## Abstract:

Aeromotive Technologies was formed at the request of Mean Green Racing (MGR), the UNT Formula SAE Team. Our team was tasked with holistic research and development of an aerodynamic device for the Formula SAE car. We have successfully developed a way for the MGR to efficiently research, choose, prove, manufacture and mount a rear aerodynamic device (inverted wing). MGR will now be able to use our methods and data to quickly and accurately determine the most efficient wing elements and aerodynamic end plates for their situation and prove their theoretical efficiency before manufacturing using advanced simulations verified by manual calculations. Our team also identified the most economical manufacturing methods based on MGR's financial restrictions and manufacturing capabilities. Finally, we used MGR's current chassis models to design a mounting method consistent with their current rules and mechanical restrictions.

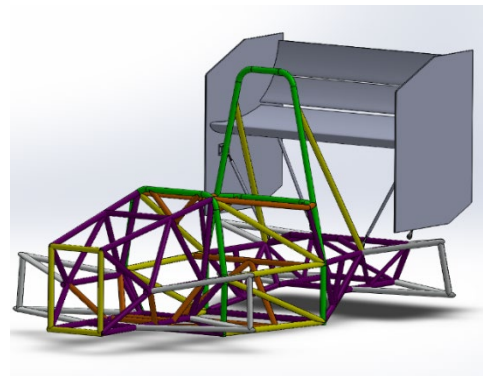

We would like to thank our advisor Dr. Manzo for supporting us throughout this project and special thanks to research assistant Chris Mullins for his help with Ansys Simulations.



CLASS PAYS



**B&P**  
PROCESS SOLUTIONS, INC.

# Peterbilt Cab Air Tester B & P Process Solutions

## Team Members:

- Brandon Thieme
- Pramson Kurien

## External Sponsors/Mentors:

- Peterbilt Motor Company
- Thomas Ford
- Tyrone Thompson

## Internal Sponsors/Mentors:

- Dr. Hector R. Siller

## Abstract:

The brake check process is critical for Peterbilt and the safety for everyone on the roadways. Due to the importance of this check, it is crucial for the operators performing the test to not be distracted or have anything that would interfere with their performance. Unfortunately, that is not the case for Peterbilt right now. On average, the operators performing the test will spend roughly sixty-seven seconds trying to track down and fix an air leak related to the cab of the truck. Therefore, we are currently looking to implement a cab air tester to drastically decrease the amount of non-valued time by 50-90% the operators spend fixing air leaks before being able to complete the brake test. This project will not only benefit the company and its reputation for producing safer more reliable trucks, but it will also save the company thousands of dollars in labor and warranty costs. The yearly labor savings from this air tester would be roughly \$50,000 and the warranty savings are projected to be around \$35,000.

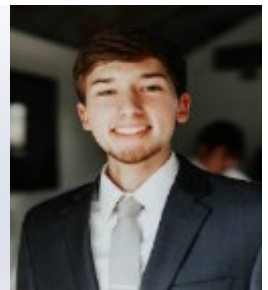
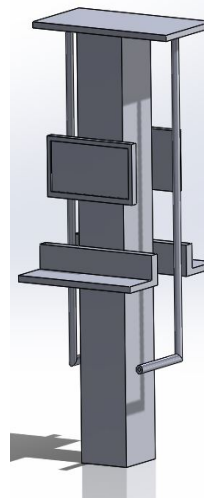



# Tolerance Analysis of Computer Aided Design (CAD) Software and Mechanical Manufacturing

## Team Members:

- Katherine Austin
- Samantha Bernal
- Thomas Cozza
- Agustin Zavala

## External Sponsors/Mentors:

- Raytheon

## Internal Sponsors/Mentors:

- University of North Texas
- Dr. Leticia Anaya

## Abstract:

Tolerance Analysis is the study of how variations in part dimensions contribute to the dimensions of a finished product or assembly. Tolerances are analyzed in order to evaluate geometric dimensioning and tolerancing (GD&T). It's important to pay attention to GD&T since incorrect tolerances can add up, costing companies time, money, and material.

We were approached by Raytheon in 2017 to help their analysis team research improve the methods used to perform proper tolerance analysis. They have pointed out that many companies are faced with the same issues concerning the parts and pieces of various components not assembling properly. The best way to find a solution to this issue by comparing the effectiveness of different CAD softwares in their ability to perform tolerance analysis. This way, we can find the most accurate software that companies can use, or at least show the pros and cons in each one. The data acquired in each software will then be compared to geometric hand calculations and theoretical ANOVA data to prove validity. This project is a continuation of the previous year's work, and is expected to continue into the 2019/2020 school year.

The tolerance analysis and dimensioning must be done in consideration of the standards depicted in ASME Y14.5-2009.

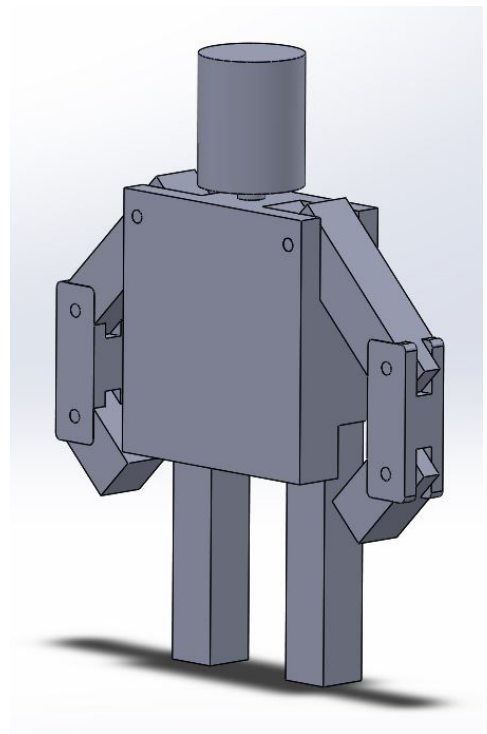





# Pressure Indicator for Fire Sprinkler

## Team 4A

### Team Members:

- Marc Chapman
- Brett Boydston

### External Sponsors/Mentors:

- American Innovative Products Incorporated

### Internal Sponsors/Mentors:

- Dr. Maurizio Manzo
- Dr. Bostanci Huseyin

### Abstract:

PIFS is a self-contained pressure indicating device that is fitted onto a new or existing fire sprinkler system. It is designed to visually indicate whether an individual fire sprinkler head is under the correct amount of water pressure as specified by the NFPA 13's codes and regulations. The device will be placed between the water pipe and the sprinkler head. When the water system is turned on, water will flow into a pipe adapter that is connected to two hydraulic pistons. As the pressure builds, the hydraulic piston rods will extend and lift the red indicator sleeve into the ceiling. If the pressure drops below the required amount for an individual sprinkler head, a spring of a certain strength inside the piston will extend, pushing the piston rod back into the piston shell and cause the indicator sleeve to drop below the ceiling. When the indicator sleeve is exposed, it is displayed as a 360-degree ring around the sprinkler head, maximizing its potential to be seen. The main objective of PIFS is to insure safe, simple, fast, and affordable ways to check if your safety system is functioning properly.





# Pressure Indicator for Fire Sprinkler

## Team 4B

### Team Members:

- Hassan Alekhwan
- Hussain Alatwah

### External Sponsors/Mentors:

- American Innovative Products Incorporated

### Internal Sponsors/Mentors:

- Dr. Maurizio Manzo
- Dr. Bostanci Huseyin

### Abstract:

Sprinkler fire systems are installed in multiple commercial buildings, retail stores, factories, institutions, etc. to extinguish fires. Currently, the sprinkler systems installed are 99% effective in preventing fires when they activate and are under the correct amount of water pressure. However, not all systems are as effective as they seem. Some sprinkler heads are not under any pressure when installed, or the heads lose their pressure, and effectiveness because the system has been previously shut off and not re-activated. As of now, there is no way to check if an individual sprinkler head is under any water pressure. In addition, the only way to check an individual sprinkler head is in case of a fire occur and that is the wrong way to test a fire system. However, after the completion of the project (pressure indicator for fire sprinklers), it will be easy to check and fix the pressure amount in each fire sprinkler head. That is, homes, companies, offices and all other buildings will be more safer with our project installed. The only way to protect lives and valued properties in case of a fire is to have PIFS in the building.

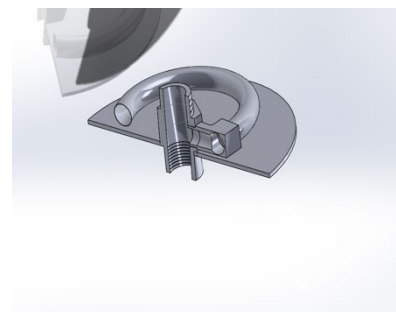

# Western Extrusions Weight Tester Team 5 Western Extrusions

## Team Members:

- Robert Dorsey
- Rashed Aleissa
- Jordan Flowers
- Nick Pena

## External Sponsors/Mentors:

- Western Extrusions

## Internal Sponsors/Mentors:

- University of North Texas, Mr. Ali Nouri

## Abstract:

Team 5's team lead Robert Dorsey managed to acquire a project from Western Extrusions. Western Extrusions extrudes long aluminum pipes that must be lifted out of the way by two employees. The lifting positions have a quick turn over of employees, require extra interviewing of prospective applicants along with extra paperwork and more potential filing of claims if an employee gets injured.

The Western Extrusions Weight Tester provides a method that saves time for Western Extrusions as it allows them to test the overall fitness of the applicants on the spot instead of taking all the applicants to the work area—the extrusion presses. In addition, the Western Extrusions Weight Tester eliminates any candidate that's not fully fit or not equipped to handle these lifting positions.

The Western Extrusions Weight Tester is relatively compact for its function. This allows Western Extrusions to change the Weight Tester's environment to wherever they feel is appropriate.

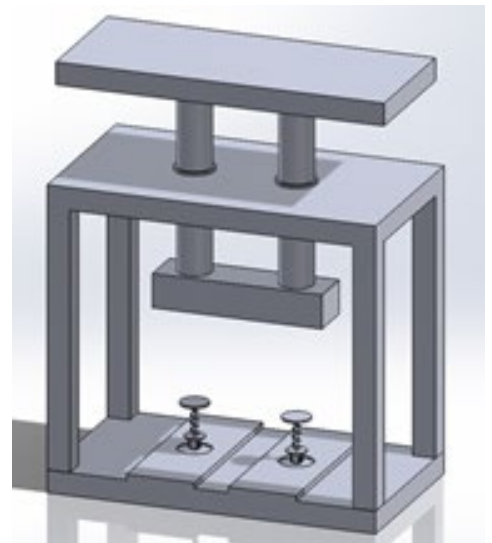



# Cam System for Wafer Cutting Operations

## Team Members:

- Jonathan , Zaragoza
- Julio, Adrian Maciel
- Johnny, Nguyen
- Majed El-Alawy
- Cristina Powell

## External Sponsors/Mentors:

- L3 Communications

## Internal Sponsors/Mentors:

- Dr. Leticia Anaya
- Dr. Hector Anaya

## Abstract:

L-3 Technologies has worked with UNT students to come up with a project that can enhance the wafer cutting process. Currently methods only allow for singular cuts to be performed on the wafers. The proposed project is to integrate a cutting tool with a table able to move in the X axis that is able to rotate 90° to achieve the desired cut pattern of a wafer. The cutting operation will consist of a first pass cut, then rotating the table 90° and finishing with a second pass cut giving the desired pattern. This operation will cut the waiting time needed for a department to wait on a chip that's needed to be worked on. The cutting tool must be precise, repeatable, and safe to avoid causing any damage to the wafer which effects it usability. A fixture will be constructed to combat this issue to maintain precision and repeatability to the wafer cutting process. A fixture will be constructed to combat this issue to maintain precision and repeatability to the wafer cutting process.



This project could not have been completed without the support and participation of L3 Communications, Dr. Leticia Anaya and Dr. Hector Siller.

# Project Pressure Wash

## Team Members:

- Carlos Moreno
- Justin Domingo
- Ali Almenayan
- Chris Morrison

## External Sponsors/Mentors:

- Jostens

## Internal Sponsors/Mentors:

- Dr. Leticia Anaya

## Abstract:

The team is manufacturing a machine that benefits the ring manufacturing company, Jostens. The machine is the combination of two of Jostens current machines that leads to an increase in efficiency and speed of the ring production. The machine cleans the tree rings by pumping hot water, 100° F, from a reservoir tank up to a set of PVC pipes, then out a set of spray nozzles. Any runoff water or loose sediment passes through a hopper into four filter bags. The remaining water returns to the reservoir tank and the cycle continues. The design process of this project consists of drafting, budgeting, sourcing materials, the first design, several redesigns and the final design.



# Hydraulic Modular Unit

## Team Members:

- Aziz Haryani
- Nicholas Ramos
- Demetrius Robertson
- Hunter Schwanebeck

## External Sponsors/Mentors:

- University of North Texas

## Internal Sponsors/Mentors:

- Dr. Cheng Yu

## Abstract:

The University of North Texas Construction Dept is expanding and improving its hydraulic unit to conduct structural testing's and make the unit mobile. The hydraulic unit created by team will be more specific and more be directed as per the requirement of the system comparatively. This system is not only beneficial for team to serve its learning purposes, but also it helps UNT structural testing lab, especially the construction major who can use this machine to conduct cold form related test. As we know UNT is well known for its construction engineering program in Texas and its structural testing lab has done multiple sponsored based projects. This structural testing system not only adds to the capabilities of the structural testing lab to cater the needs of outside projects but also aids students to be able to use it for their own educational gains. With the system requiring little to no human involvement apart from the setup, this system will be safe and easy to use.





Department of  
**MATERIALS SCIENCE  
AND ENGINEERING**

# Design of Cu-based High Temperature Shape Memory Alloys for Development and Orientation Systems in a 3U Cubesat

## Team Members:

- Faith Gantz
- Skye Segovia
- Mora Issa
- Xiaowei Wang

## External Sponsors/Mentors:

- Dr. Othmane Benafan
- Consortium for the Advancement of Shape Memory Alloy Research & Technology (CAS MART)
- National Aeronautical & Space Administration (NASA)

## Internal Sponsors/Mentors:

- Dr. Marcus L. Young
- Dr. Robert W. Wheeler
- Nathan A. Ley

## Abstract:

In this study, a set of Cu-based HTSMAs are tested to optimize the properties required to function in a 3U CubeSat. By using SMAs for this application, the overall cost of the CubeSat can be reduced. Instead of having many components to perform the actuation task, this system will use one component to perform the actuation task when exposed to solar radiation. Vacuum arc melting is used to create the alloys. A hot- and/or cold-rolling/drawing process is used to convert the alloys to wire. Samples which show potential for meeting the project requirements are further heat treated to produce the bamboo structure, improving the overall quality of the SMA. Characterization of the samples is performed at various steps of the project and involves differential scanning calorimetry (DSC), scanning electron microscopy (SEM) equipped with energy dispersive spectroscopy (EDS), Vickers hardness, X-ray Diffraction (XRD), and thermo-mechanical testing.

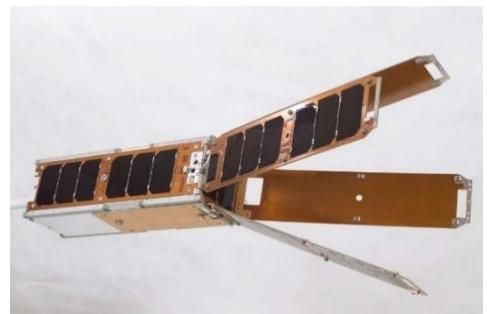

University of North Texas Materials Research Facility (MRF)

Advanced Photon Source, a U.S. Department of Energy (DOE) Office of Science User Facility operated for the DOE Office of Science by Argonne National Laboratory



# Design Process for LENS Manufacturing of Hiperco Soft Magnets

## Team Members:

- Ashley Carter
- Jiawei Miao
- Juan Umana

## External Sponsors/Mentors:

- Lex Seneff, Senior Motor Design Engineer, Moog Inc.

## Internal Sponsors/Mentors:

- Dr. Raj Banerjee

## Abstract:

Hiperco, an alloy of Fe and Co, is a commonly used soft magnetic material in electronic devices. With the ever-decreasing size of these devices, the magnetic components also need to decrease in size. Laser Engineered Net Shaping (LENS) is an additive manufacturing process that lets us create small and complex geometries that may not be achieved through conventional manufacturing. The downside to LENS is the thermal gradient associated with the building of the component. This can cause the loss of desired properties, in this case a soft magnet. The objective of this project is to optimize the design process for LENS manufactured Hiperco to keep the material as a soft magnet. This is done through altering the deposition parameters and through post-deposition heat treatments.



## • Acknowledgments:

- David Flannery
- Mohan Sai Kiran Kumar Yadav Nartu
- Srinivas Aditya Mantri
- Hitesh Adhikari

# Ionic Liquid Non-Hydrolytic Sol-Gel Process For Near Zero Thermal Expansion Ceramic Powder Synthesis

## Team Members:

- Kyle Rose
- Mutaz Fallatah
- Austin Everett

## External Sponsors/Mentors:

- Dr. Victoria Blair, Army Research Laboratory (ARL-CQL Mentor)

## Internal Sponsors/Mentors:

- Dr. Rick Reidy (MTSE Advisor)

## Abstract:

Ionic Liquids commonly used in electrodeposition of metals are adopted into the Non-Hydrolytic Sol-Gel Route for the purposes of synthesizing near zero thermal expansion ceramic powders. The purpose of this design is to utilize a known method of ionizing metal chlorides in the known synthesis route for near zero thermal expansion ceramics. The use of 1-Ethyl-3-Methylimidazolium Chloride to create a Lewis basic Ionic Liquid with  $AlCl_3$  and  $WCl_6$  has shown the ability to synthesize  $Al_2W_3O_{12}$  when mixed with Benzyl-alcohol in a dry inert atmosphere. This reaction creates a sol-gel that is considered a "raw" Sample. After calcination at  $1100^\circ C$  for 3 hours the sample shows phase uniformity under XRD and EDS mapping with correct stoichiometry. Particle size of the sample is  $\sim 4\mu m$ . The calcined powder was then pressed and sintered. Dilatometry was then performed on the sample to show the thermal expansion. The development in new synthesis routes can be used to create thermal shock resistant transparent materials for application in the aerospace industry.



Acknowledgement: Jessie Smith – Assistance in SEM imaging and mapping

# Solid state diffusion bonding optimization using SPS and PVD

## Team Members:

- Trevor DeNicholas
- Rebecca Fox
- Tingyu Huang

## External Sponsors/Mentors:

- Army Research Lab

## Internal Sponsors/Mentors:

- Dr. Tom Scharf
- Dr. Nigel Shepherd
- Hunter Lide

## Abstract:

Diffusion bonding was used to adhere low-density, ceramic SiC and B4C samples. This process was optimized by use of an interfacial material. Due to the mismatch of the coefficient of thermal expansion between the two materials, surface cracking is a significant problem faced when using laminate methods to bond these samples. Trends in literature show that the presence of microcracking after bonding low-density ceramics can be reduced by decreasing the thickness of the interfacial material. This method was applied to the bonding of dissimilar ceramics and has shown a significant reduction in defects and surface cracking.

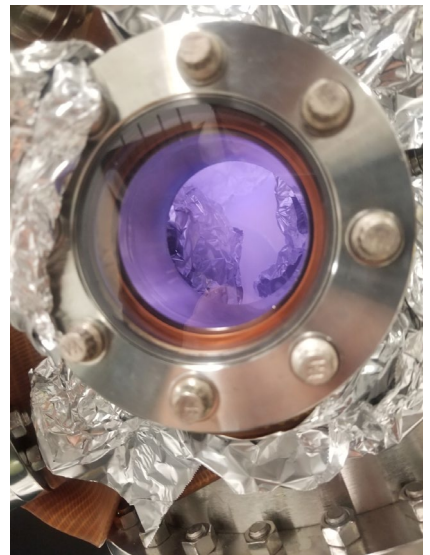



Department of  
**MECHANICAL AND  
ENERGY ENGINEERING**

## 9 ACES – Sanden Intl.

### Team Members:

- Ghithi Alkalbani
- Mohamed Allafi
- Tavyn Brooks
- Edgar Gonzalez
- Francisco Mendoza IV
- Christopher Morel
- Shaima Qaddoura
- Runtian Tang
- Robert Thomas IV

### External Sponsors/Mentors:

- Company: Sanden Intl. USA

### Internal Sponsors/Mentors:

Mentors:

- Dr. Mark Wasikowski
- Dr. Tae Choi
- Robbin Shull
- Rick Pierson

### Abstract:

Sanden Intl. is a company that manufactures refrigerant compressors for the automotive industry. Due to strict regulations, the metallic shavings created during the assembly process exceeded the maximum specifications.

Our goal was to reduce/eliminate the contamination found inside the compressors. Through our brainstorming and analysis we determined three potential solutions focused around the adjustment screw.

By solving this issue, we would drastically reduce the amount of time and money spent on cleaning and fixing the alignment in their current production line. The solutions we have designed so far are unlike anything previously thought of within the company and geared towards a very specific issue in the automotive industry.



Special thanks to Scott Worley & Greg Maurer from Sanden Intl., Dr. Wasikowski, Dr. Choi, Robbin Shull, Rick Pierson and the entire faculty and staff from UNT for their guidance, assistance, & support.

# AlumaPower Tech

## Team Members:

- Hunter French
- Mary Njoroge
- William Pena
- Scott Wood

## External Sponsors/Mentors:

- Paul Simpson
- Goeff Sheerin
- AlumaPower

## Internal Sponsors/Mentors:

- Dr. Reid
- Dr. Glaser
- Dr. Wasikowski

## Abstract:

The AlumaPower Tech design team was tasked with developing improvements to metal air batteries by looking into designs of the cathode. To do this, the team designed and constructed a test fixture to control and test different cathode designs inside the cell as well as design and fabricate different methods of creating cathode.

# Apogee Automatic Vise Adaptor – Team Apogee

## Team Members:

- Cody Beall
- Abdallah Al Tobi
- Ali Aldulajjan
- Abdulrahman Alqahtani
- Austin Engler
- Joshua Kovach

## External Sponsors/Mentors:

- All Axis Machining
  - Cristian Almendariz
  - Dave Perkowski

## Internal Sponsors/Mentors:

- Dr. Wasikowski
- Dr. Glaser

## Abstract:

A workshop that uses CNC/Milling machines to produce parts will use vises to keep the parts steady during operation. These vises are usually manually tightened by the operator/machinist. Automated options exist to replace these vises, but these options can be very expensive.

Our project aims to create an adaptor that fits on basic “legacy” vises to turn them automated. This adaptor would be operational with a simple USB or Ethernet connection to a computing unit. The ultimate goal being that a machine shop could get several adaptors to help propel them into a fully automated future at a fraction of the cost.



We would like to thank our professors at UNT, everyone at All-Axis Machining and all of our fellow students and family who have helped us get to this point.



# Team ASHRAE – Energy Recovery Ventilator Coupled with Phase Change Materials

## Team Members:

- Sidney Hartz
- Sergio Turrubiarres
- Marybeth Fuhlman
- Matthew Rushing
- Dacen Kinser
- Parker Walvoord

## External Sponsors/Mentors:

- American Society of Heating, Refrigerating, and Air-Conditioning Engineers (ASHRAE)

## Internal Sponsors/Mentors:

- Dr. Weihuan Zhao

## Abstract:

Heating, ventilation, and air conditioning (HVAC) systems typically account for approximately 40% of building energy consumption. The goal of this project was to design an energy recovery ventilator (ERV) with enhanced heat transfer capabilities through the use of phase change materials (PCM). PCM is embedded in cylindrical spokes which are evenly spaced across an aluminum honeycomb matrix heat transfer wheel.



Team ASHRAE is grateful for Dr. Weihuan Zhao's mentorship throughout the duration of this project. Furthermore, we would like to thank Dr. Mark Wasikowski and Dr. Radek Glaser for the guidance they provided as professors of Senior Design. We appreciate Dr. Xiaohua Li for allowing us to use some of his equipment for testing our design. Finally, this project would not be possible without the funding given to us by ASHRAE.



# Team Fluids

## Team Members:

- Juan Christiansen
- Nicholas Brennan

## External Sponsors/Mentors:

- University of Texas, Mechanical and Energy Department

## Internal Sponsors/Mentors:

- Dr. Hamid Sadat
- Dr. Wasikowski

## Abstract:

Our project creates a visual aid of fluid flow through a pipe network that demonstrates how the flow is affected by a sample of common pipe components and configurations by measuring the head loss and comparing it to theoretical value. In addition, the network allows for the visualization of the velocity boundary layer within the pipe through the use of food coloring, in addition with the comparison of it with a smooth vs rough case. The network is compatible to test the thermal boundary layer as well through the use of a heater, which the users can calculate theoretically.



We would like to thank Dr. Wasikowski and Dr. Glaser for their guidance in the process, in addition to Robbin Shull for his knowledge.



# GE Bootleggers/Team 2

## Team Members:

- Trung Nguyen
- Mohamed Boualaoui

## External Sponsors/Mentors:

- Luis Matos/ GE
- Geoff Faltot/GE

## Internal Sponsors/Mentors:

- Dr. Radek Glaser
- Dr. Mark Wasikowski

## Abstract:

- Solving the Air Caster problem from tipping on one side
- Find the new solution to move the Inverter from station 1 to 2 and 3 for final assembly

# Team: GE Bootleggers

## Team Members:

- Diego Santos
- Efrain Huerta
- Charles Miller
- Sakina Al Lawat

## External Sponsors/Mentors:

- GE Transportation:
- Luis Matos
- Geoffery Faltot

## Internal Sponsors/Mentors:

- Dr. Mark Wasikowski
- Dr. Radek Glaser

## Abstract:

Inverters are navigated via air floats through a production line which may become stuck when passing over the seams in the concrete floor and create a safety hazard for workers operating the system. Our engineering team designed a prototype transportation cart to test 12" diameter twergo casters along with two 8" motorized casters to verify if the system is able to function with the required weight of 10,500 lbs. This transportation cart also includes an inverter frame, hydraulic frame, hydraulic rams and bottom frame. The hydraulic frame was tested by adding 8,625lbs of weight and verified the movement and the capacity of the frame. Another solution was to add pressure regulators for each airbag in current air float table.





# Seed-Planting UAV

## The Math Magicians

### Team Members:

- Hamza Hasham
- John McEntire
- Steven Molinaro
- Andrew Renzetti
- John Verret

### External Sponsors/Mentors:

- The Math Magicians

### Internal Sponsors/Mentors:

- Hamza Hasham – The Math Magicians

### Abstract:

Today, deforestation is taking place at an alarming rate. In 2017, enough trees to cover a football field were knocked down every single second. The Math Magicians propose a project to build an autonomous drone with a pressure-chamber that plants seeds to help counter the global carbon footprint.



We would like to thank the entire UNT faculty and staff in being so helpful with the students. We would like to specifically acknowledge: Dr. Wasikowski, Dr. Glaser, Erin Allice, Rick Pierson, Robbin Shull, and the Student Lab Assistants for their dedication to the Capstone Projects.

## Mountain Plumbing

### Team Members:

- Sergio Gonzalez
- Omar Aleid
- Ahmed Al-Saadi
- Abdul Al Sukaiti
- Hussain Altaweel

### External Sponsors/Mentors:

- Oran, Baldwin (Mountain Plumbing Products)

### Internal Sponsors/Mentors:

- Dr. Haifeng Zhang

### Abstract:

The problem with the garbage disposal is that it makes a loud noise of 73 decibels at start up. Our goal was to reduce the noise while still maintaining the lifetime warranty. This loud noise is caused by the impellers hitting the metal bump at a high speed. There were several different designs done too deliver a quieter result while still maintaining a lifetime warranty. A quieter sounding garbage disposal will disturb the customer less .People often call the company asking if its broken due to the loud noise at start up.



# NASA CASMART

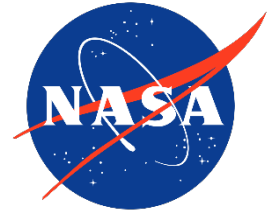

## Team Members:

- Kelsa Adams
- Jordan Barnes
- David Evers
- Michael Ayers
- Robert Boone
- Brittany Thurstin

## External Sponsors/Mentors:

- CASMART
- NASA – Dr. Othmane Benafan
- Fort Wayne Metals – Drew Forbes
- Classic Steel LLC

## Internal Sponsors/Mentors:

- Dr. Robert Wheeler
- Dr. Marcus Young
- Dr. Richard Zhang

## Abstract:

The purpose of our project is to design and fabricate a mechanism to passively orient solar panels on a CubeSat using shape memory alloys (SMA). A CubeSat is a shoebox sized satellite that can be used for a variety of planetary missions such as research, imaging, and surveillance. SMAs are smart materials that can be trained to remember a particular geometric orientation. If deformed, the material will return to its trained orientation upon heating above its transformation temperature. Redundant solar arrays are often attached to many or all sides of a CubeSat, but only one or two may be producing power at any given time; hence, more power can be supplied to the CubeSat using deployable solar arrays controlled with SMA actuators. SMAs provide a mechanical advantage over traditional motors by reducing design complexity, power consumption, volume, and weight. This reduction in size and weight coupled with increased available power to the CubeSat broadens the scope of possible scientific applications aboard the satellite. We designed and fabricated separate mechanisms for retention, deployment, and actuation of the solar panels in addition to a test apparatus and true scale model of a 3U CubeSat.

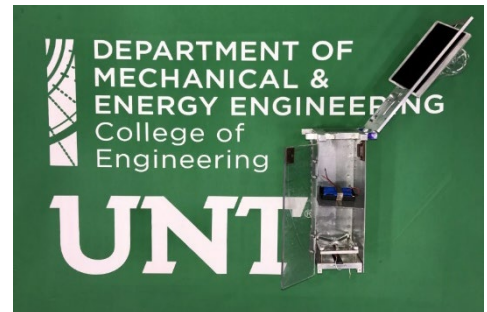

# Rivet Heads

## Team Members:

- Garrett Blank
- Katelin Dulack
- Jacques Pantano
- Blaine Ware

## External Sponsors/Mentors:

- Triumph Aerospace Structures (mentor)

## Internal Sponsors/Mentors:

- Dr. Mark Wasikowski

## Abstract:

Currently, the aerospace industry installs ten of thousands of rivets by hand. Proper rivet installation requires a smooth, precise hole to be drilled prior to rivet placement. We have created an end effector for the UR10 that can (1) drill a hole for the rivet and (2) buck the rivet. Our design is unique in that it uses a pneumatic control system to stabilize the end effector as it drills through aircraft-grade aluminum. Our design will replace the mundane work of installing rivets by hand and will eliminate human error that causes an unstable drill and rivet gun.



# Universal Jig / Triumph Group

## Team Members:

- Matt Loyd
- Sam Giuffre
- Brice Gabel
- Anthony Le

## External Sponsors/Mentors:

- Don, Surratt

## Internal Sponsors/Mentors:

- Dr. Hamid Sadat

## Abstract:

Universal Jig to house and rotate leading edges of Boeing 767 for polishing.







**Triumph Group, Inc.**

# Triumphant

## Team Members:

- Hunter Bolton
- Bridger Planz
- Fernando Duran
- Joshua Sullivan
- Elliot Nirider
- Fawzi Obeidat

## External Sponsors/Mentors:

- Triumph Group Aerospace Structures
- Don Surratt
  - Gary Pekar

## Internal Sponsors/Mentors:

- Dr. Cherish Qualls

## Abstract:

Triumph's current leading-edge polishing process takes between 4-8 hours per portion of leading edge of a Boeing 747 and is done manually. To automate the process our team used a collaborative robot (UR10) and have designed two end effectors to be used for a two-phase polishing process. The robot was then programmed for each end effector to polish the leading edge. The first phase end effector is a large drum polisher and is used on the entire piece to remove small imperfections and the second phase end effector is a small wheel polisher used for the edges and deep scratches. The goal of automating the process is to polish the leading edge to roughly 50% finish and cut down polishing time by half per segment. Implementation of this process will provide more time for the polishing overseer to work on other tasks and cut down cost.

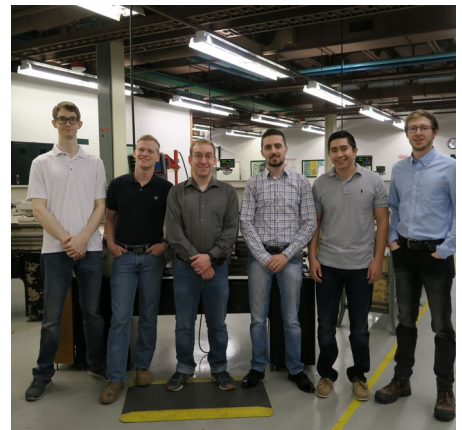

Thank you to Rick Pierson, Boddy Grimes and TA's for guiding us in the fabrication process.

# SAE Ergonomics

## - Mean Green Racing 2018-2019

### Team Members:

- Adam Strouhal
- Joshua Fumagalli
- Salim Al Hamadani
- Saif Al Harrasi
- Ammar Salim Said Al Saidi

### External Sponsors/Mentors:

- Peterbilt (sponsor)
- American Waterjet Products (sponsor)

### Internal Sponsors/Mentors:

- UNT MEEN Department (sponsor)
- Dr. Hyeonu Heo (faculty advisor)
- UNT Mean Green Racing (sponsor)

### Abstract:

SAE Ergonomics 2018-2019 is a team of five students responsible for conceiving, designing, engineering, manufacturing, and testing a package of components and systems required to create and operate a competitive FSAE racing car. The components we produce pertain to the steering, transmission, braking, and engine throttle control systems all of which are directly controlled or engaged by the driver. This year we are aiming to improve the manufacturability of components by simplifying designs, reducing part counts, and the number of milling operations and increasing the resilience of our parts to manufacturing defects. Designing the components we produce to be less sensitive to defects facilitates a broader scope and increases the permissible testing time; something our sponsor Mean Green Racing greatly appreciates.



We would like to acknowledge the Engineering Technology department for continuing its support and contributions to Mean Green Racing. None of this would be possible or feasible without the lab space that has been graciously allocated to the race team for the past 7 years.

# FSAE - Suspension

## Team Members:

- Matthew Atkins
- Adam Bragg
- Matt Fehrle
- Zachary Holmans

## External Sponsors/Mentors:

- American Waterjet
- Peterbilt
- RBC bearings
- QA1

## Internal Sponsors/Mentors:

- Mean Green Racing
- Dr. Xiaohua Li
- Dr. Hector Siller

## Abstract:

The University of North Texas Formula SAE team competes annually as part of SAE International's Collegiate Design Series in Lincoln, Nebraska. This year the FSAE Suspension Senior Design team sets its sights on improving suspension packaging and kinematics, while also simplifying manufacturing processes and reducing weight. Expedient fabrication and assembly will allow the team ample testing time and maximum opportunity to meet their competition goals. The parts designed for the project include suspension point jigs, control arms, bell-cranks, anti-roll bars, tabs, pull-rods, and tie-rods.

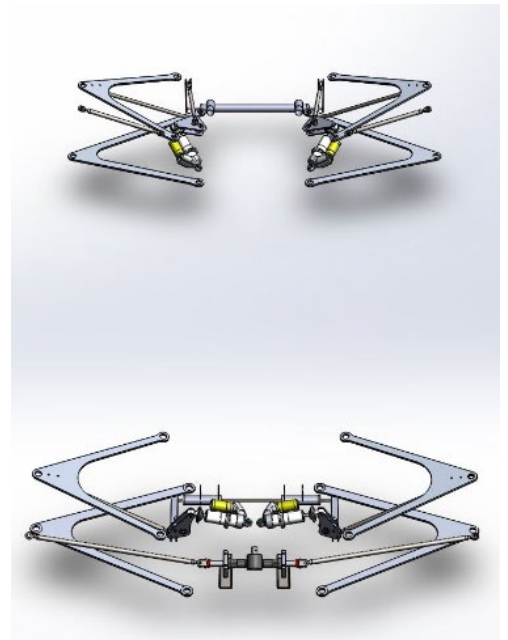



# MEEN Green Thermoclean

## Team Members:

- Samuel, Bach
- Brandon, Kelling
- David Avants
- Luis Hernandez
- Mahmood Al Shabibi

## External Sponsors/Mentors:

- NatureShield Co.

## Internal Sponsors/Mentors:

- Dr. Cherish Qualls

## Abstract:

The main scope of our project was to take an outdated Thermoclean steam cleaning machine and to make it UL certified. A few things that were stopping the machine from being UL certified are that machine was using too much electricity, had incompatible electrical cords, and the machine case was made out of fiberglass which is not a UL approved material. The team found all of the errors with the machine that was keeping it from being UL certified and redesigned a new Thermoclean machine made out of aluminum that is more efficient and most importantly qualified to be UL certified.



# Welding with a Twist

## Team Members:

- Yousef Akil
- Meagan Bunck
- Juan Ibarra
- Sheena Lindorm
- Stephanie Lopez
- Saul Morales
- Alejandra Sifuentes

## External Sponsors/Mentors:

- AC Horn Manufacturing - Michael Horn
- Guillermo Herrera
- Fernando Duarte
- Addiel Sital
- Liam Muhlholland

## Internal Sponsors/Mentors:

- Dr. Radek Glaser
- Dr. Mark Wasikowski

## Abstract:

The purpose of Welding with a Twist is to create a program and mechanical system to facilitate TIG welding with a Universal Robot. By using a Universal Robot to automate the welding of spirals, our company's lead time will be reduced by at least 60%.

Robotic welding has been around since the 1960's and is mostly popular in today's automotive industry. The industry mostly uses MIG arc welding with robots, and it's mostly only for spot welding. Our project is unique because it is applying continuous TIG welding, which requires a more complex design.

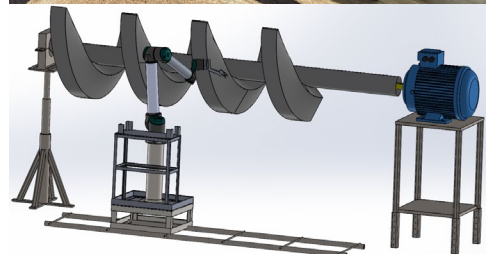

Special thanks to Rick Pierson, Sheldon Aminzadeh, Wyatt Verret

# UNT Zodiac Seats

## Team Members:

- Cullen Gray
- Joel Koo
- Cody Stewart
- Yousif Alnahash
- Christina Rapert
- Salim Al Tamtami
- Wes Burks
- Katelyn Sotello

## External Sponsors/Mentors:

- Zodiac Seats, US
- Safran Seats, US

## Internal Sponsors/Mentors:

- Dr. Mark Wasikowski

## Abstract:

Team UNT Zodiac was tasked with automating preliminary steps of the assembly of an airline seat. This is accomplished by utilizing two robotic arms. The first assembly steps involve placing 8 components together and screwing them together to meet specifications.

The project utilizes two Universal Robotics Co-bots, a CB-UR10 and a CB-UR3. The UR10 utilizes a 2F-85 gripper while the UR3 utilizes a HAND-E gripper, both from the robotics company Robotiq.

The assembly of the airline seat is aided by a shadowbox that the frame of the seat rests on. This shadowbox provides a base reference to start the assembly process.

In addition to the shadowbox, multiple organizers were manufactured to serve as stationary reference points.

Custom gripper fingers were fabricated to better handle parts of the airline seat frame.

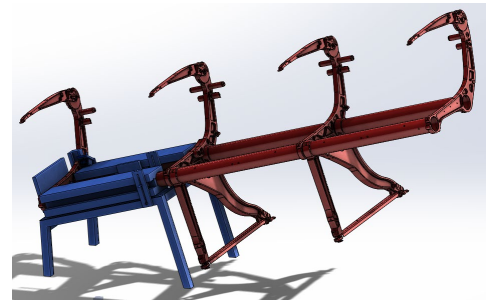

## Thanks to:

Robin Shull

Erin Alice

Sheldon Aminzadeh

Natarsha Hall



@UNTEngineering

[www.engineering.unt.edu](http://www.engineering.unt.edu)  
940.565.4300